

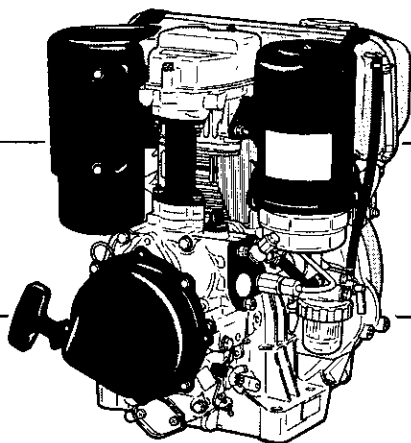

MODEL

DY30D/30B DY35D/35B
DY41D/41B DY42D/42B

INSTRUCTIONS for USE



ISSUE EMD-EU1093











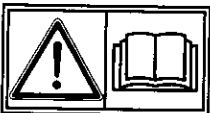
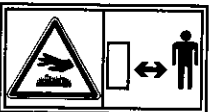



2ZZ9020057

Robin Engines

CONTENTS

| | |
|------------------------------------|----|
| 1. SAFETY PRECAUTIONS | 1 |
| 2. COMPONENTS | 4 |
| 3. PRE-OPERATION CHECKS | 6 |
| 4. ELECTRIC STARTER MODELS | 9 |
| 5. ADVICE ON BELT DRIVING | 11 |
| 6. OPERATING YOUR ENGINE | 12 |
| 7. EASY TROUBLESHOOTING | 15 |
| 8. MAINTENANCE SCHEDULE..... | 17 |
| 9. "HOW-TO" MAINTENANCE | 18 |
| 10. PREPARATIONS FOR STORAGE | 22 |
| 11. SPECIFICATIONS | 23 |

SYMBOLS

| | | | |
|---|-------------------|---|--|
|  | | <i>Read the owner's manual.</i> | |
|  | | <i>Stay clear of the hot surface.</i> | |
|  | | <i>Exhaust gas is poisonous. Do not operate in an unventilated area.</i> | |
|  | | <i>Stop the engine before refueling.</i> | |
|  | | <i>Fire, open flame and smoking prohibited.</i> | |
|  | <i>On (Run)</i> |  | <i>Plus; Positive polarity</i> |
|  | <i>Off (Stop)</i> |  | <i>Battery</i> |
|  | <i>Engine oil</i> |  | <i>Engine start (Electric start)</i> |
|  | <i>Add oil</i> |  | <i>Stop</i> |
|  | <i>Fast</i> |  | <i>Diesel fuel</i> |
|  | <i>Slow</i> | | |

1. SAFETY PRECAUTIONS

Please make sure you review each precaution carefully.

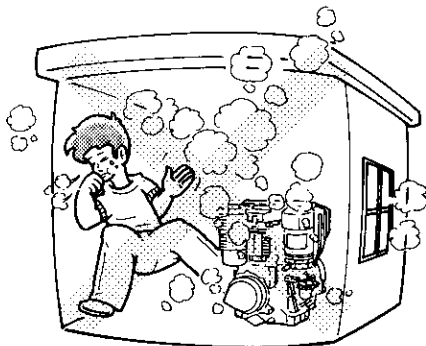

EXHAUST PRECAUTIONS

- Never inhale exhaust gasses. They contain carbon monoxide, a colorless, odorless and extremely dangerous gas which can cause unconsciousness or death.
- Never operate the engine indoors or in a poorly ventilated area, such as tunnel, cave, etc.
- Exercise extreme care when operating the engine near people or animals.
- Keep the exhaust pipe free of foreign objects.

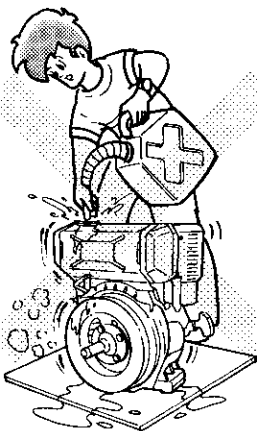

REFUELING PRECAUTIONS

- Be sure to stop the engine prior to refueling.
- Do not overfill the fuel tank.
- If fuel is spilt, wipe it away carefully and wait until the fuel has dried before starting the engine.
- After refueling, make sure that the fuel cap is secured to prevent spillage.

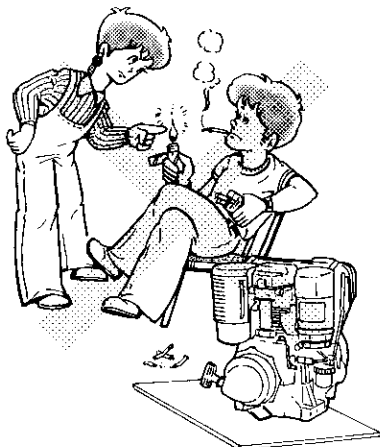

FIRE PREVENTION

- Do not operate while smoking or near an open flame.
- Do not use around dry brush, twigs, cloth rags, or other flammable materials.
- Keep the engine at least 3 feet (1 meter) away from buildings or other structures.
- Keep the engine away from flammables and other hazardous materials (trash, rags, lubricants, explosives).

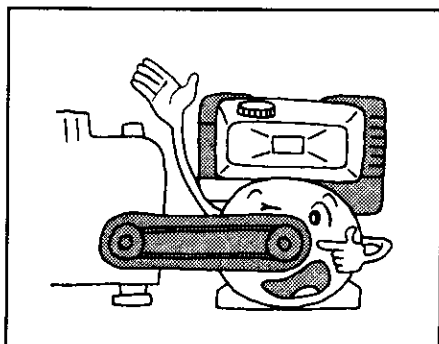

PROTECTIVE COVER

- **Place the protective covers over the rotating parts.**

If rotating parts such as the drive shaft, pulley, belt, etc. are left exposed, they are potentially hazardous. To prevent injury, equip them with protective covers or shrouds.

- **Be careful of hot parts.**

The muffler and other engine parts become very hot while the engine is running or just after it has stopped. Operate the engine in a safe area and keep children away from the running engine.

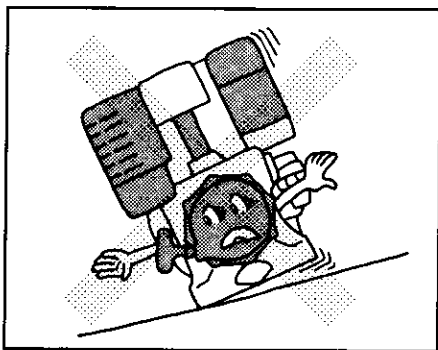

SURROUNDINGS

- **Operate the engine on a stable, level surface free of small rocks, loose gravel, etc.**

- **Operate the engine on a level surface.**

If the engine is tilted, fuel spillage may result.

NOTE :

Operating the engine at a steep incline may cause seizure due to improper lubrication even with a maximum oil level.

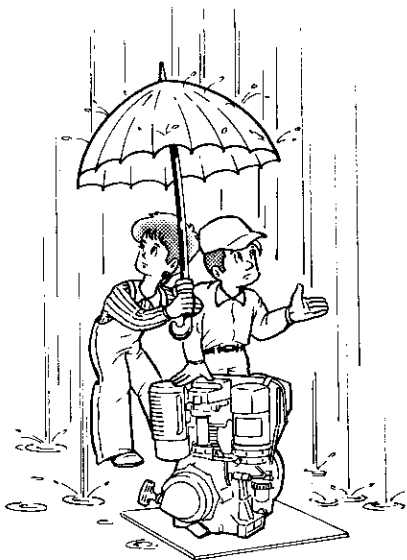

- **Be careful of fuel spillage when transporting the engine.**

Tighten the fuel tank cap securely and close the fuel strainer cock before transport.

- **Do not move the engine while in operation when it has been removed from the equipment.**

- When the engine is transported over a long distance or on rough roads, drain fuel from fuel tank to prevent fuel leakage.

PRE-OPERATION CHECKS

- Carefully check fuel pipes and joints for looseness and fuel leakage. Leaked fuel creates a potentially dangerous situation.

- Check bolts and nuts for looseness. A loose bolt or nut may cause serious engine trouble.

- Check the engine oil and refill if necessary.

- Check the fuel level and refill if necessary. Take care not to overfill the tank.

- Wear snug fitting working clothes when operating the engine. Loose aprons, towels, belt, etc., may be caught in the engine or drive train, causing a dangerous situation.

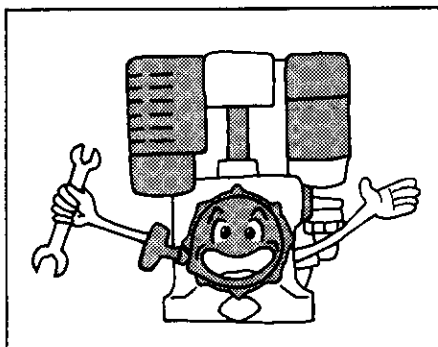

2. COMPONENTS

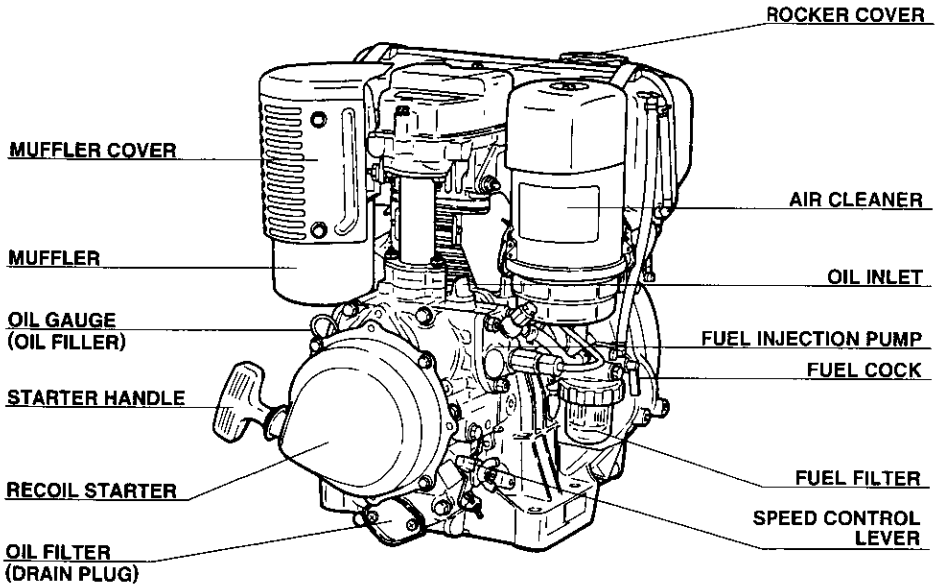

This illustration shows D type.

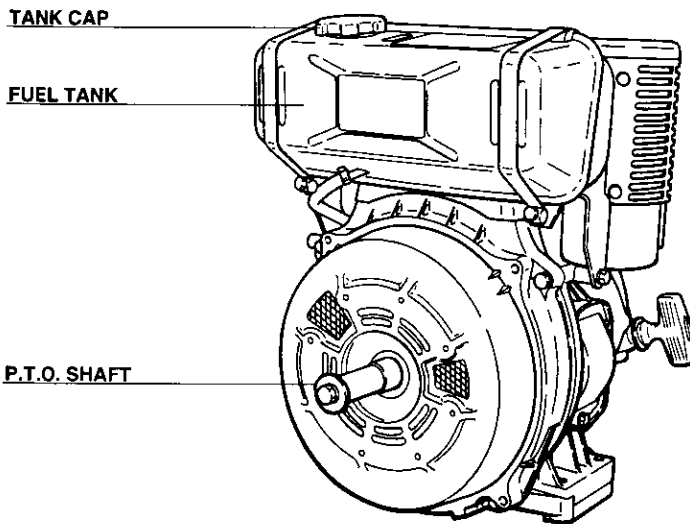

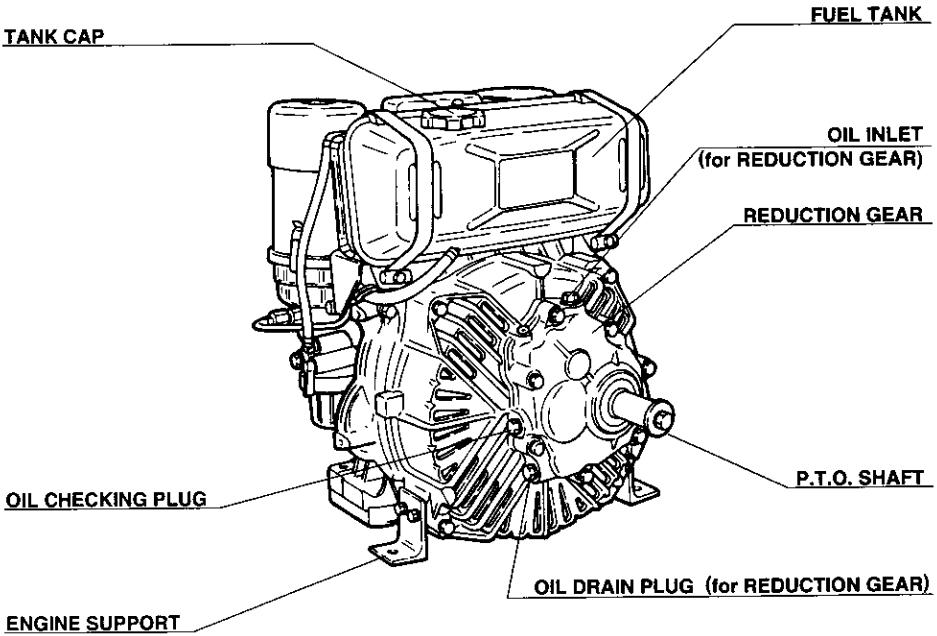

This illustration shows B type.

3. PRE-OPERATION CHECKS

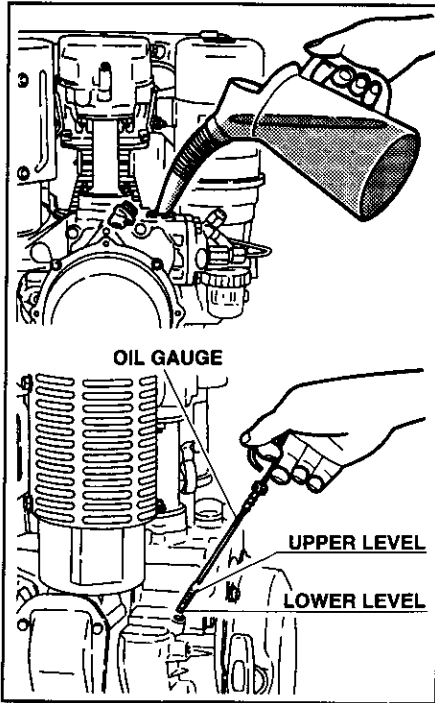

FILLING ENGINE OIL

Place the engine horizontally and pour oil up to the upper level of the oil gauge (approx. 1 liter).

- Use diesel engine oil with a viscosity of :

| SEASON or TEMPERATURE | GRADE OF OIL |
|---|--------------|
| Spring or Summer or Autumn +104°F (40°C) to +50°F (10°C) | SAE30 |
| +68°F (20°C) to +14°F (-10°C) | SAE10W-30 |

Oil grades of "CC" or "CD" (API classification) are recommended. Inferior quality engine oil and/or lack of oil may cause a piston seizure.

CAUTION

**Do not use gasoline engine oil.
Use diesel engine oil only.**

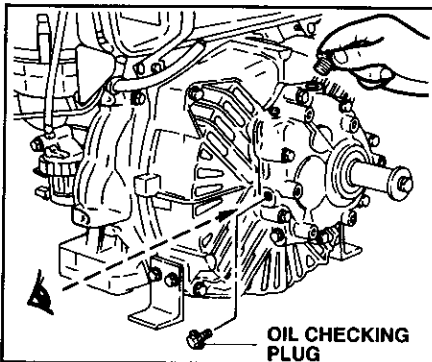

CHECKING ENGINE OIL FOR REDUCTION TYPE

Place the engine horizontally. Remove the plug for oil checking hole and check the oil level. If the oil is about to flow over the hole, it is sufficient for the quantity specified (approx. 220cc).

- Overfilling may cause oil spouting out of the breather.
- Use diesel engine oil specified in the above table.

FILLING FUEL IN FUEL TANK AND DISCHARGE AIR FROM FUEL SYSTEM

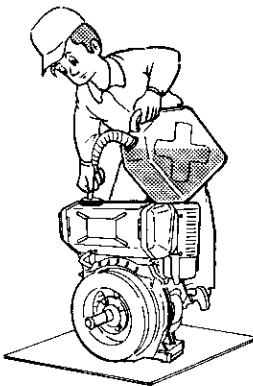
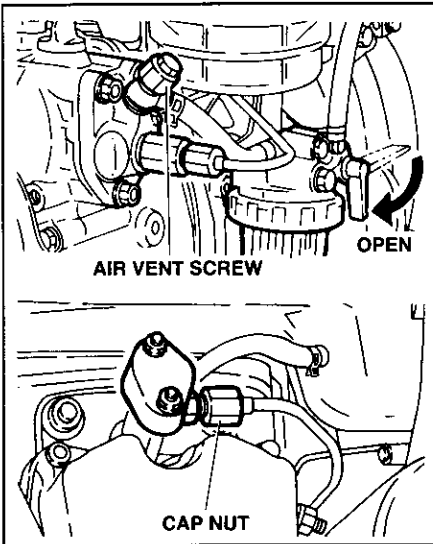

- Use light automobile diesel fuel.
- Fuel should be clean and fresh. Fuel around the bottom of drum contains dirt, impurities and water. If contaminated fuel is used, the fuel injection pump and nozzle may be clogged.
- Fuel tank capacity is 4,5 liters. If the fuel is spilt while refilling, wipe off thoroughly.
- When starting the engine in the following conditions, air venting from fuel line is required.
 1. Starting the brand new engine for the first time.
 2. Restarting the engine after the engine has stopped due to fuel shortage.
 3. Starting the engine after fuel filter cleaning.
- Air venting procedure
 1. Open the fuel cock.
 2. Loosen the air vent screw of the fuel injection pump and let fuel flow out until air bubbles no longer appear.
 3. After completing the above work, retighten the air vent screw.
 4. Set the speed control lever at the "high" speed position and loosen the cap nut on the side of the nozzle and pull the recoil starter handle slowly until sufficient fuel has been injected.
 5. Retighten the cap nut.
- Stop the engine first, then refill fuel.

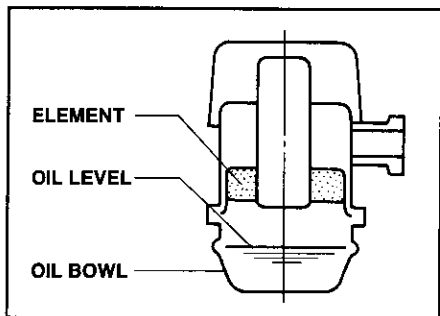

FILLING ENGINE OIL IN OIL BATH AIR CLEANER

- Pour in engine oil up to the specified level in the oil bowl.

NOTE :

Oil bath air cleaner is not available for DY42D/B.

4. ELECTRIC STARTER MODELS

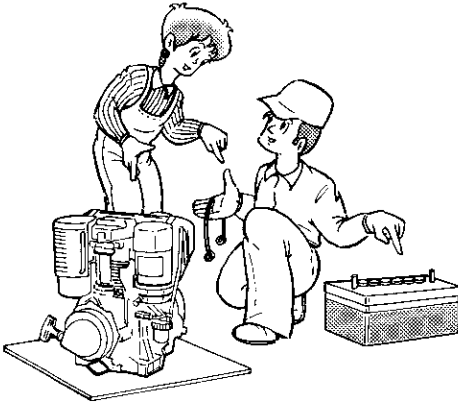

1. PREPARE THE FOLLOWING

- (1) Battery with a capacity of 12V-35AH or larger.
- (2) Lead wires for connecting battery, starter switch and starting motor.

a) BATTERY CABLE

| CABLE LENGTH | CABLE DIA. | WIRE GAUGE | | |
|----------------|------------|-------------|-----|------|
| | | AWG(BS) BWG | SAE | JIS |
| Less than 1.5m | 7.3mm | 1 | 6 | AV15 |
| 1.5m to 2.5m | 8.5mm | 0 | 4 | AV20 |
| 2.5m to 4m | 10.8mm | 3/0 | 2 | AV30 |

b) SWITCH CABLE

When remote key switch is used, select wires of proper gauge to connect key switch and magnetic switch on the engine.

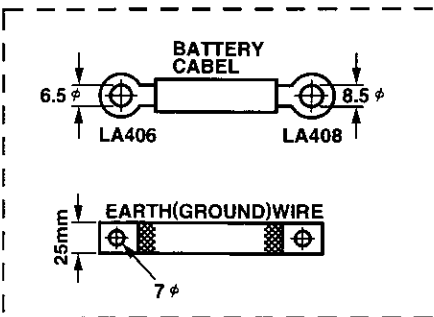

| CABLE LENGTH | CABLE DIA. | WIRE GAUGE | | |
|----------------|------------|-------------|-----|--------|
| | | AWG(BS) BWG | SAE | JIS |
| Less than 1.5m | 1.5mm | 14 | 16 | AV1.25 |
| 1.5m ~ 3.5m | 1.9mm | 12 | 14 | AV2 |
| 3m ~ 5m | 2.4mm | 10 | 13 | AV3 |

c) GROUND WIRE

Use a flat braided wire of 0.03 sq. in. (20mm²) or larger sectional area.

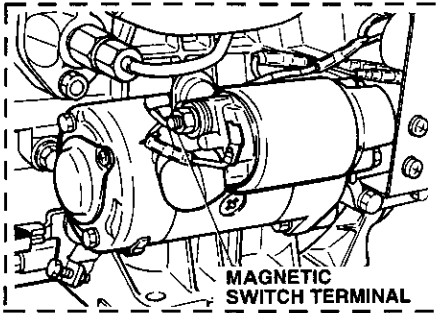

2. WIRING

1. Connect (+) terminal of the battery and magnetic switch terminal with a battery cable.
2. Connect (-) terminal of the battery to a grounded part of the engine or the equipment with a ground wire.

NOTE :

Tighten bolts and nuts on terminals securely so that they would not be loosened by vibration.

WIRING DIAGRAM

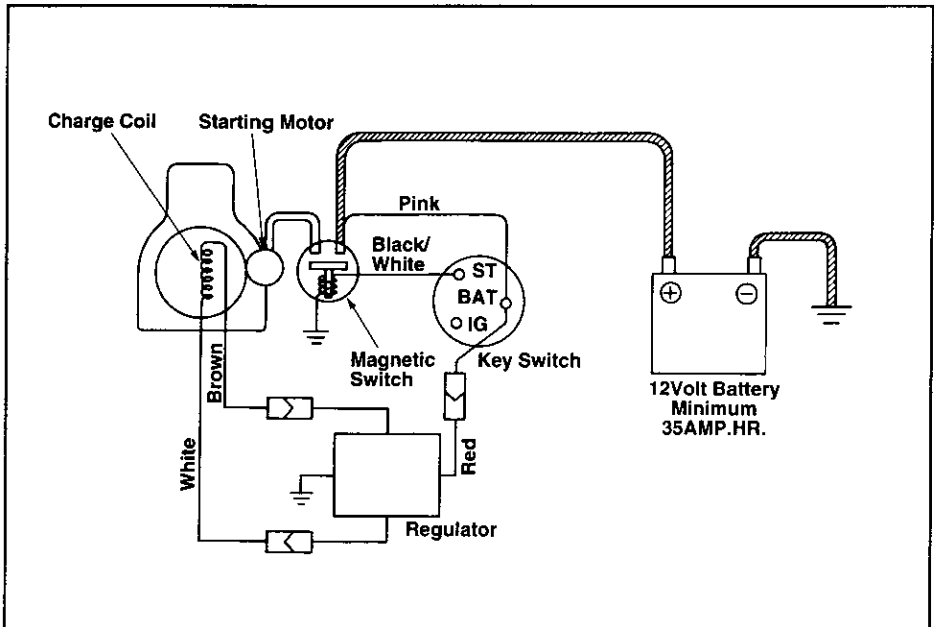

5. ADVICE ON BELT DRIVING

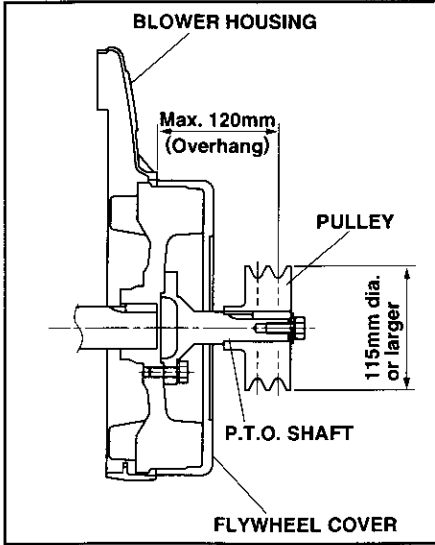

When your engine is used for powering the equipment by a belt drive system, be sure to observe the following recommendations in order to use the engine efficiently, safely and comfortably for a long time.

1. PULLEY SIZE AND INSTALLATION

- (1) Use a double groove V-pulley with 115 mm diameter or larger for the drive pulley. Smaller pulley will cause belt slipping.
- (2) The overhang distance between the blower housing and the center of the outer groove of the drive pulley must be less than 120 mm.

If this overhang distance is larger, the engine runs a risk of getting heavy damage such as breakage of crankshaft or main bearings.

2. RECOMMENDED BELT

| | |
|---------|-------------------|
| Belt | V-belt type "B" |
| Numbers | 2 (Use in double) |

3. TENSION FOR BELT

Adjust the belt tension so as that the belt allows 1.6 mm deflection per 100 mm center distance between drive and driven pulleys when the middle of the belt is depressed with a finger. For example, when the center distance of pulleys is 500 mm, proper tension is to allow deflection by 8 mm.

$$\left(1.6 \text{ mm} \times \frac{500}{100} = 8 \text{ mm} \right)$$

Too much tension will cause heavy starting and breakage of crankshaft and bearings.

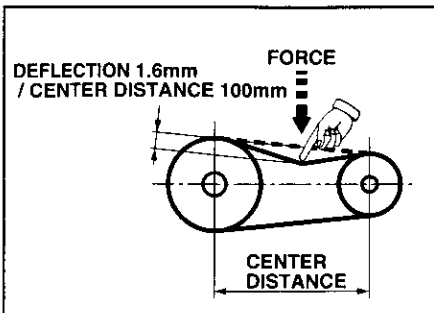

6. OPERATING YOUR ENGINE

STARTING

FUEL COCK

1

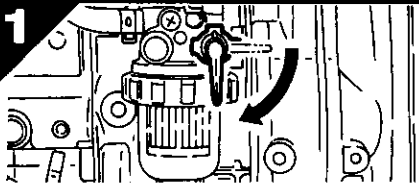

Open the fuel cock.

SPEED CONTROL LEVER

2

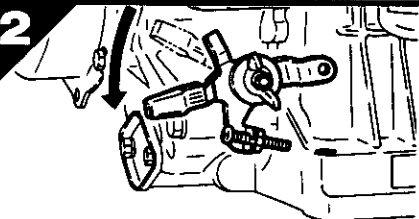

Set the speed control lever at the HIGH SPEED position.

RECOIL STARTER

3

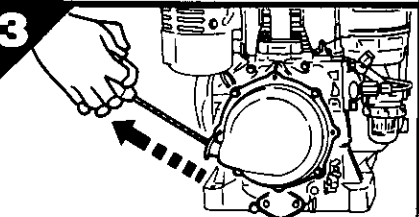

- Pull the starter handle slowly until resistance is felt. This is the "compression" point. Return the starter handle to its original position and repull swiftly.
- Do not pull out the rope all the way.
- After starting the engine, allow the starter handle to return to its original position while still holding the handle.

KEY SWITCH (Electric Starter) (Starting by key switch)

3

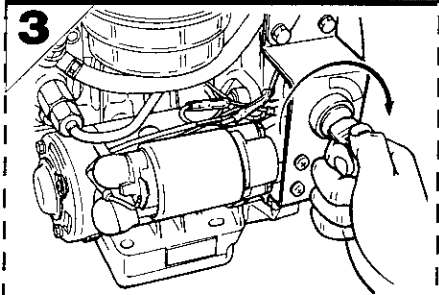

Insert the key into the key slot and turn it to the RUN (I) position. Turn it to the right (START position) to start the engine.

- Do not operate the electric starter continuously for more than 5 seconds, even if the engine does not start.
- If the engine failed to start, set the key to the RUN (I) position and wait for about 10 seconds before retrying.
- Never turn the key switch to the position START while the engine is running.

RUNNING

SPEED CONTROL LEVER

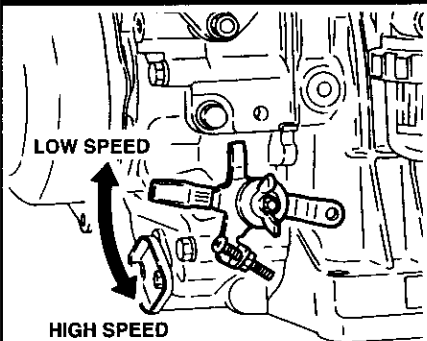

After the engine started, set the speed control lever at the LOW speed position and warm it up without a load for a few minutes.

Gradually move the speed control lever toward the HIGH speed position and set it at the required engine speed.

NOTE :

Whenever high speed operation is not required, slow the engine speed down (idle) by moving the speed control lever to save the fuel and extend the engine life.

STOPPING

SPEED CONTROL LEVER (D type)

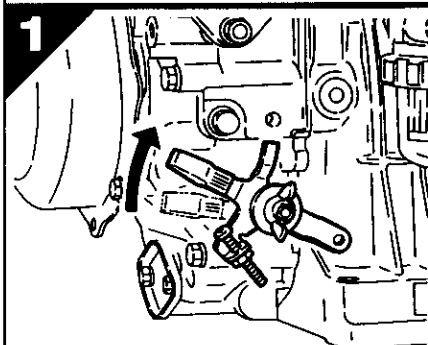

Set the speed control lever at the low speed position and allow the engine to run at low speed for 2 or 3 minutes before stopping. Set the speed control lever to "STOP" position to stop engine.

STOP LEVER (B type) (Stopping by Stop Lever)

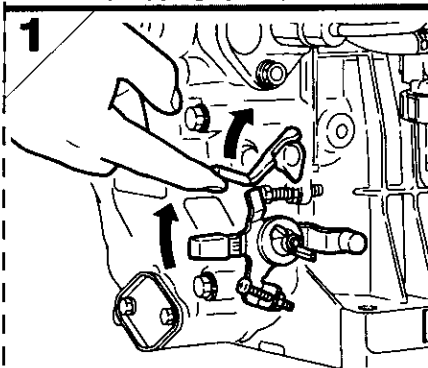

Run the engine at idle speed for a few minutes to cool down, and pull up the stop lever until the engine stops.

FUEL COCK

2

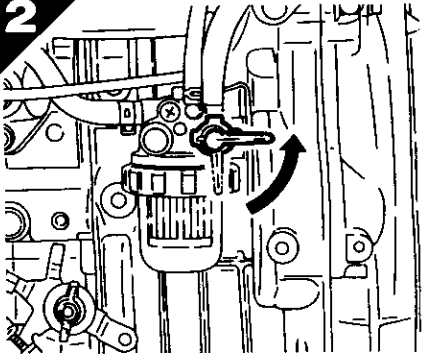

Close the fuel cock.

KEY SWITCH

(Electric Starter)

2



After the engine stops, set the key switch at the STOP (O) position and remove the key.

NOTE :

Note that when the key is either at the STOP position or is being pulled out of the key switch while engine is running, the battery is not being charged.

7. EASY TROUBLESHOOTING

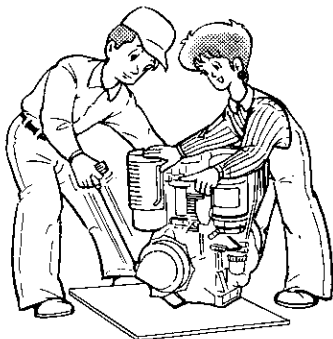

WHEN ENGINE DOES NOT START !

- Perform the following checks before you take the engine to your Robin dealer.
- If you still have trouble after completing the checks, take the engine to your nearest dealer.

Are foreign substances contained in the fuel?

1. Drain all the fuel from the fuel tank and check that no foreign substances and/or water are contained in the fuel.
2. Clean the fuel filter.

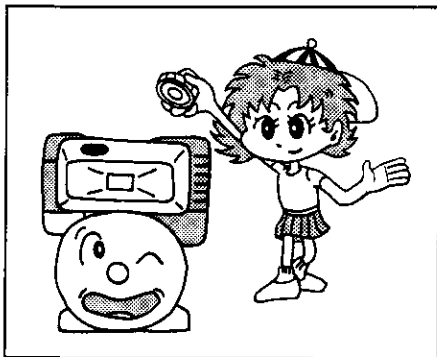

Is your battery well charged ?

1. If the battery for the electric starter is discharged, the engine does not start. Change the battery then try starting again.
2. Check wiring, especially connectors for tightness.

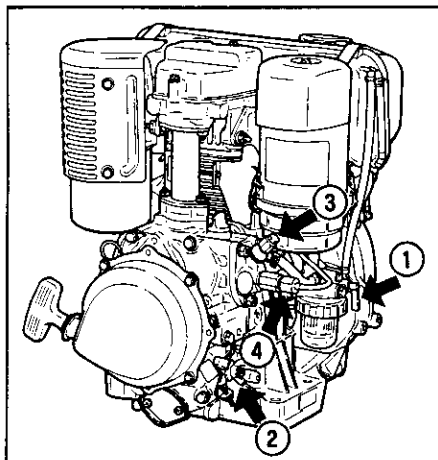

Is fuel being injected ?

1. Check that the fuel cock is open.
2. Check that the speed control lever is in the "HIGH SPEED" position.
3. Loosen the air vent screw of the injection pump and let the air out of the pump.
4. Disconnect the high pressure pipe on the side of the injection pump, and set the speed control lever to the "HIGH SPEED" position.
Turn the engine over manually and check if fuel is injected. If the fuel is not being injected, the dealer or service shop should repair the unit.

Is there enough compression ?

1. If compression is not sufficient, check the mounting of the injection nozzle. If the mounting nuts are loose, tighten them.

8. MAINTENANCE SCHEDULE

DAILY INSPECTION

Before running the engine, check the following service items.

If you notice any trouble during operation, stop the engine immediately and consult your dealer.

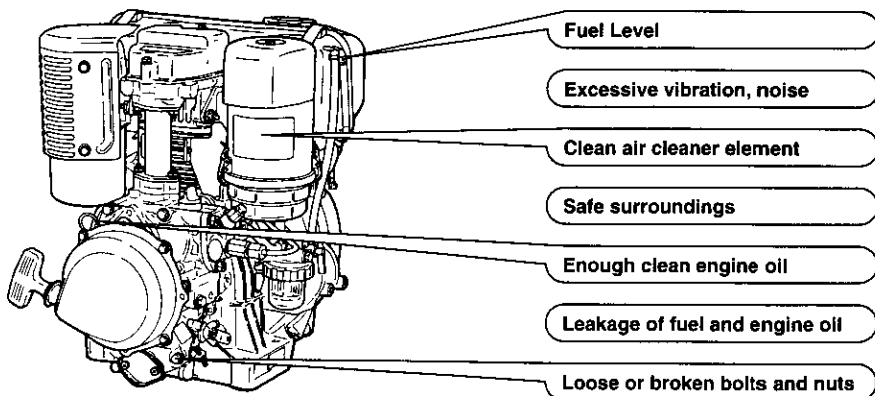

PERIODIC INSPECTION

Periodic maintenance is vital to the safe and efficient operation of your engine.

Check the table below for periodic maintenance intervals.

The following chart is based on the normal engine operation schedule.

● This mark indicates that special tools and skills are required. Consult your dealer.

| Items | Operating hours | 8 hours (daily) | 100 hours | 500 hours | 1000 hours |
|--|-----------------|--------------------------------------|-------------|--------------|------------|
| Check for oil and fuel leakage | | ○ | | | |
| Check bolts and nuts for tightness | | ○ | | | |
| Check engine oil | | ○ Refill everyday up to upper level. | | | |
| Replace engine oil | | ○ Initially 25 hrs. | ○ | | |
| Clean air cleaner and add oil | | | ○ | | |
| Check and adjust valve clearance | | | | ● | |
| Clean fuel filter (Remove contaminants and water) | | | | ○ (300 hrs.) | ○ Replace |
| Replace or clean oil filter | | | ○ | | |
| Check nozzle and clean | | | | ● | |
| Check valve seat | | | | | ● |
| Reduction oil change (B type) | | | | ○ (300 hrs.) | |
| Check battery electrolyte level | | | ○ (monthly) | | |

9. "HOW-TO" MAINTENANCE

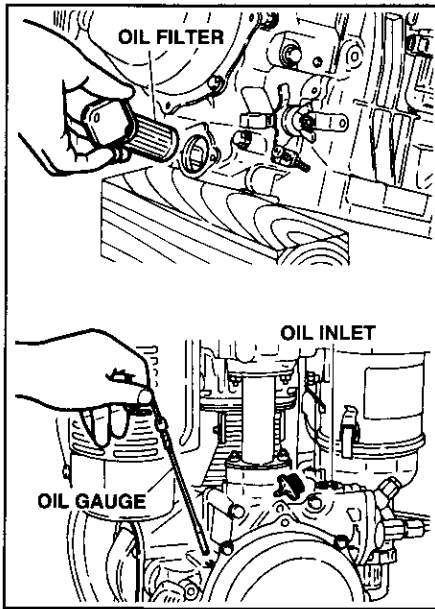

ENGINE OIL CHANGE AND OIL FILTER CLEANING

- Initial oil change
..... After 25 hours of operation
 - Thereafter
..... Every 50 hours of operation
1. While the engine is still warm, remove the oil filter.
 2. Assemble oil filter after drain engine oil.
 3. Pour the engine oil up to upper level of the gauge and run engine for several minutes. Then, stop engine and let it stand for about 10 minutes. Check the oil level again and add if necessary. (Capacity : approx 1 liter)
 4. When changing oil, clean the oil filter with diesel fuel.

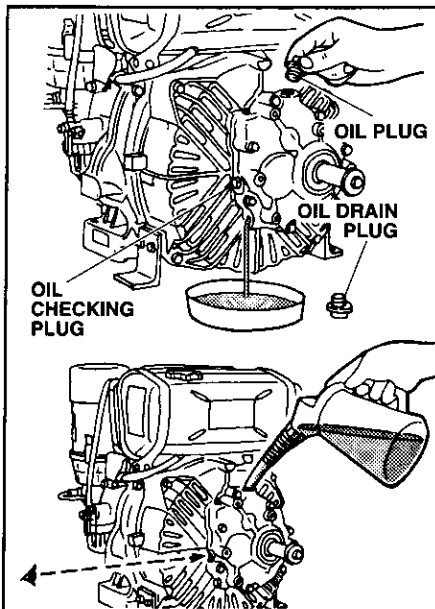

OIL CHANGE FOR REDUCTION GEAR BOX

CAUTION

Overfilling may cause oil to spout out of the breather. So, be careful.

- Use diesel engine oil for reduction gear oil.
 - Period of oil change
..... Every 300 hours of operation
1. While the engine is warm, remove the drain plug.
For quick draining, remove the plug of the oil inlet.
 2. When filling up the oil, first tighten the drain plug firmly, and remove the oil checking plug. Place the engine on a level surface and pour the oil in until it overflows from the oil checking plug.

CLEANING AIR CLEANER

OIL BATH AIR CLEANER

If the air cleaner is dirty, the engine will perform poorly due to fresh air intake resistance. Always keep the air filter clean.

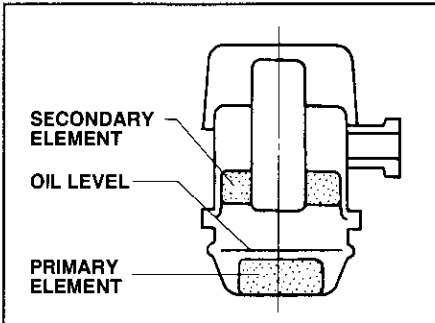

1. After every 100 hours of operation, disassemble and clean the primary and secondary elements with diesel fuel. After cleaning, coat the secondary element with engine oil.

2. Replenish engine oil up to oil level.

- When operating the engine under extremely dusty conditions, clean the air filter every 30~50 hours of operation depending on the operating conditions.

DUAL ELEMENT AIR CLEANER

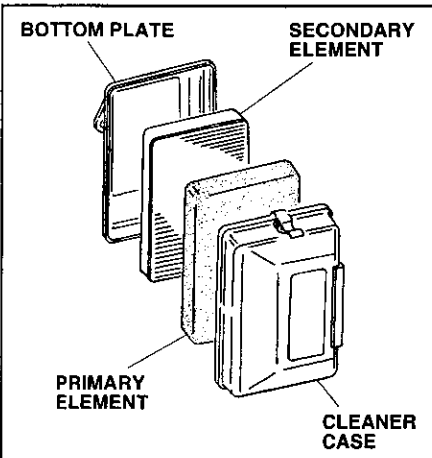

CAUTION

Do not wash elements with kerosene, gasoline or oil.

If the air cleaner is dirty, the engine will perform poorly due to air intake resistance. Always keep the air cleaner elements clean.

- After every 100 hours of operation, disassemble and clean the primary and secondary elements with detergent. After cleaning, dry them and attach.
- When operating the engine under extremely dusty conditions, clean the air cleaner elements every 30 to 50 hours of operation depending on the operating conditions.

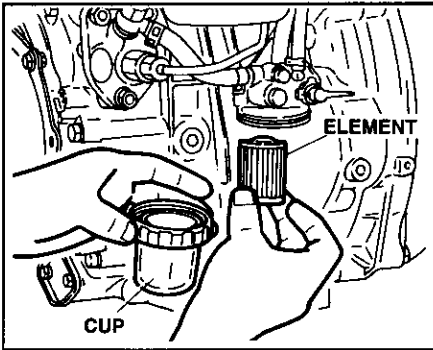

CLEANING FUEL FILTER

Fuel injection pump is a very precise mechanism. If dust or water is contained in the fuel, the plunger may be damaged or seized up. Therefore, clean the fuel filter element and cup very carefully.

1. If and when water and/or foreign substances are found in the fuel filter cup, remove the cup and clean it.
 2. After every 200 hours of operation, clean the fuel filter and after every 500 hours of operation, replace the elements with new ones.
- Close the fuel cock before cleaning.
 - After cleaning bleed the air out of the fuel system. (Refer to page 7.)

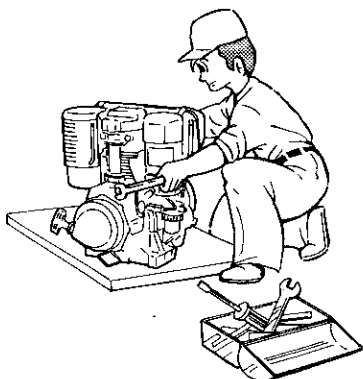

CHECKING BOLTS, NUTS AND SCREWS

- Retighten loose bolts and nuts.
 - Check for fuel and oil leaks.
 - Replace damaged parts with new ones.
- Keep safety on your mind.

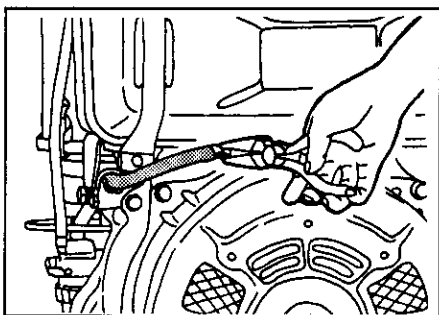

FUEL PIPE REPLACEMENT

Replace the fuel pipe every 2 years.
When fuel leak is found, replace it immediately.

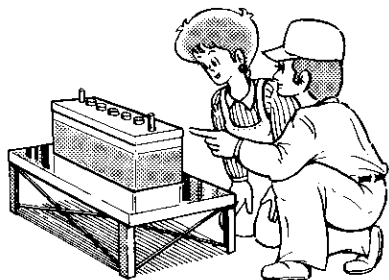

CHECK BATTERY

If the electrolyte is below the level line, refill with distilled water to the upper level line.

10. PREPARATIONS FOR STORAGE

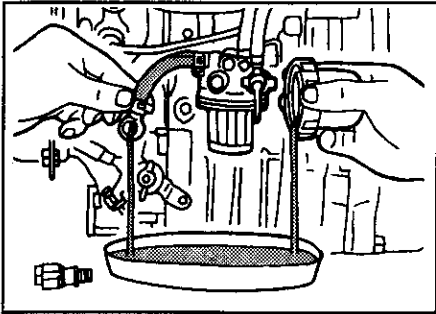

DISCHARGE FUEL (NO SMOKING !)

- Remove the injection pump bolt and discharge the fuel from the fuel tank.
- Remove the fuel filter cup and discharge fuel from the fuel filter.
- After discharging the fuel, clean the fuel filter element.

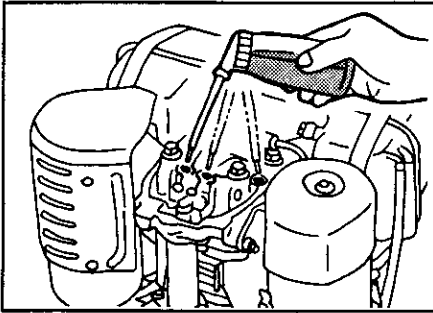

ENGINE LUBRICATING OIL

- Exchange the old engine oil with fresh oil.
- Remove the rocker cover, and lubricate rocker arm and valves. Lubricate hole on the side of the cleaner. Gently rotate the engine for two or three times, and tighten the rocker cover.

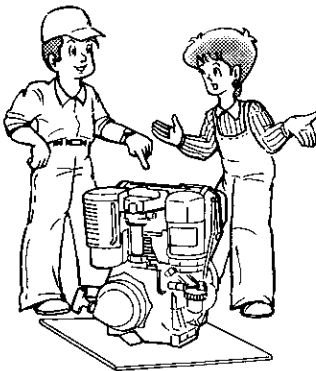

CLEAN AND STORE

- Pull the starter handle slowly until resistance is felt and leave it in that position.
- Disconnect the battery and charge it.
- Wipe the engine thoroughly with an oiled cloth, put the cover on, and store the engine indoors in a well-ventilated, low humidity area.

BATTERY CHARGING

- The battery discharges itself even when not connected, therefore it is necessary to recharge it once a month.

11. SPECIFICATIONS

| MODEL | DY30D | DY30DS | DY30B | DY30BS | DY35D | DY35DS | DY35B | DY35BS | |
|-----------------------------|--|--------------------------|---|--------------------------|---|--------------------------|---|--------------------------|--------|
| Type | Air-cooled, 4-Cycle, Vertical, Overhead Valve, Single Cylinder Diesel Engine | | | | | | | | |
| Displacement | 299 cm ³ | | | | 348 cm ³ | | | | |
| DIN6270NA | 3.7kW/3000min ⁻¹ (5.0 HP/3000rpm) | | 3.7kW/1450min ⁻¹ (5.0 HP/1450rpm) | | 4.4kW/3000min ⁻¹ (6.0 HP/3000rpm) | | 4.4kW/1450min ⁻¹ (6.0 HP/1450rpm) | | |
| | 4.0kW/3600min ⁻¹ (5.5 HP/3600rpm) | | 4.0kW/1750min ⁻¹ (5.5 HP/1750rpm) | | 4.8kW/3600min ⁻¹ (6.5 HP/3600rpm) | | 4.8kW/1750min ⁻¹ (6.5 HP/1750rpm) | | |
| DIN6270NB | 4.4kW/3000min ⁻¹ (6.0 HP/3000rpm) | | 4.4kW/1450min ⁻¹ (6.0 HP/1450rpm) | | 5.2kW/3000min ⁻¹ (7.0 HP/3000rpm) | | 5.2kW/1450min ⁻¹ (7.0 HP/1450rpm) | | |
| | 4.8kW/3600min ⁻¹ (6.5 HP/3600rpm) | | 4.8kW/1750min ⁻¹ (6.5 HP/1750rpm) | | 5.5kW/3600min ⁻¹ (7.5 HP/3600rpm) | | 5.5kW/1750min ⁻¹ (7.5 HP/1750rpm) | | |
| Direction of Rotation | Counterclockwise as viewed from P.T.O. shaft side | | | | | | | | |
| Lubricant | Diesel Engine Lubricating Oil API classification "CC" or "CD" grade | | | | | | | | |
| Fuel | Automotive Diesel Fuel | | | | | | | | |
| Fuel Tank Capacity | Approx. 4.5 L | | | | | | | | |
| Lighting Capacity (V-W/rpm) | - | 12-29/3000 12-31/3600 | - | 12-29/1450 12-31/1750 | - | 12-29/3000 12-31/3600 | - | 12-29/1450 12-31/1750 | |
| Starting System | Recoil Starter | Electric Starter | Recoil Starter | Electric Starter | Recoil Starter | Electric Starter | Recoil Starter | Electric Starter | |
| Dry Weight | 37 kg | 45 kg | 43 kg | 51 kg | 37 kg | 45 kg | 43 kg | 51 kg | |
| Dimensions | Length | 436 mm | 436 mm | 497 mm | 447 mm | 436 mm | 436 mm | 497 mm | 447 mm |
| | Width | 370 mm | 408 mm | 370 mm | 408 mm | 370 mm | 408 mm | 370 mm | 408 mm |
| | Height | 450 mm | 450 mm | 450 mm | 450 mm | 450 mm | 450 mm | 450 mm | 450 mm |

Specifications are subject to change without notice.

| MODEL | DY41D | DY41DS | DY41B | DY41BS | DY42D | DY42DS | DY42B | DY42BS | |
|------------------------------------|--|--------------------------|---|--------------------------|---|--------------------------|---|--------------------------|--------|
| Type | Air-cooled, 4-Cycle, Vertical, Overhead Valve, Single Cylinder Diesel Engine | | | | | | | | |
| Displacement | 412 cm ³ | | | | | | | | |
| DIN6270NA | 5.2kW/3000min ⁻¹ (7.0 HP/3000rpm) | | 5.2kW/1450min ⁻¹ (7.0 HP/1450rpm) | | 5.7kW/3000min ⁻¹ (7.6 HP/3000rpm) | | 5.7kW/1450min ⁻¹ (7.6 HP/1450rpm) | | |
| | 5.5kW/3600min ⁻¹ (7.5 HP/3600rpm) | | 5.5kW/1750min ⁻¹ (7.5 HP/1750rpm) | | 6.3kW/3600min ⁻¹ (8.5 HP/3600rpm) | | 6.8kW/1750min ⁻¹ (8.5 HP/1750rpm) | | |
| DIN6270NB | 6.0kW/3000min ⁻¹ (8.0 HP/3000rpm) | | 6.0kW/1450min ⁻¹ (8.0 HP/1450rpm) | | 6.5kW/3000min ⁻¹ (8.7 HP/3000rpm) | | 6.5kW/1450min ⁻¹ (8.7 HP/1450rpm) | | |
| | 6.3kW/3600min ⁻¹ (8.5 HP/3600rpm) | | 6.3kW/1750min ⁻¹ (8.5 HP/1750rpm) | | 7.0kW/3600min ⁻¹ (9.4 HP/3600rpm) | | 7.0kW/1750min ⁻¹ (9.4 HP/1750rpm) | | |
| Direction of Rotation | Counterclockwise as viewed from P.T.O. shaft side | | | | | | | | |
| Lubricant | Diesel Engine Lubricating Oil API classification "CC" or "CD" grade | | | | | | | | |
| Fuel | Automotive Diesel Fuel | | | | | | | | |
| Fuel Tank Capacity | Approx. 4.5 L | | | | | | | | |
| Lighting Capacity (V-W/rpm) | — | 12-29/3000 12-31/3600 | — | 12-29/1450 12-31/1750 | — | 12-29/3000 12-31/3600 | — | 12-29/1450 12-31/1750 | |
| Starting System | Recoil Starter | Electric Starter | Recoil Starter | Electric Starter | Recoil Starter | Electric Starter | Recoil Starter | Electric Starter | |
| Dry Weight | 46 kg | 53 kg | 50 kg | 57 kg | 47 kg | 54 kg | 51 kg | 58 kg | |
| Dimensions | Length | 436 mm | 436 mm | 497 mm | 447 mm | 436 mm | 436 mm | 497 mm | 447 mm |
| | Width | 370 mm | 408 mm | 370 mm | 408 mm | 394 mm | 408 mm | 394 mm | 408 mm |
| | Height | 478 mm | 478 mm | 478 mm | 478 mm | 478 mm | 478 mm | 478 mm | 478 mm |

Specifications are subject to change without notice.

OPTIONAL PARTS

P.T.O. shaft and adapter for generator
P.T.O. shaft and adaptor for pump
Throttle wire bracket

One touch speed control lever
(Dust-proof cover is also available).
Updraft (Downdraft) muffler with tail pipe
Large capacity fuel tank (15 L)
Lighting coil

 **FUJI HEAVY INDUSTRIES LTD.**

INDUSTRIAL PRODUCTS COMPANY

4-410 Asahi, Kitamoto-shi,

Saitama, 364-8511, Japan

Phone +81(48) 593-7798

Fax +81(48) 593-7946

Web site <http://www.fhi.co.jp/robin/>