

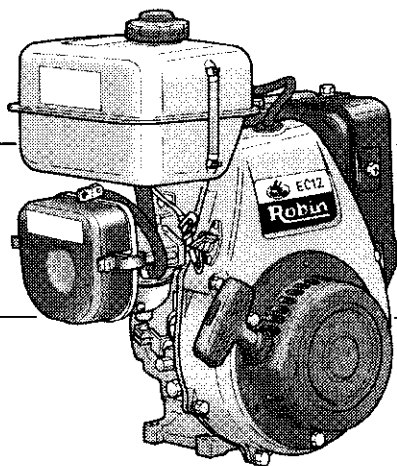

MODEL

EC12

**INSTRUCTIONS FOR USE
MANUEL D'UTILISATION
BEDIENUNGSANLEITUNG
GEBRUIKSAANWIJZING
MANUAL DE INSTRUCCIONES
MANUAEL D'USO E MANUTENZIONE**



CE1/英·仏·独·蘭·西·伊

ISSUE EMD-EU1517

1ZZ9990010

Robin Engines

CONTENTS

1. SAFETY PRECAUTIONS	1
2. COMPONENTS	4
3. PRE-OPERATION CHECKS	6
4. OPERATING YOUR ENGINE	7
5. EASY TROUBLESHOOTING	13
6. MAINTENANCE SCHEDULE	15
7. "HOW-TO" MAINTENANCE	16
8. PREPARATIONS FOR STORAGE	18
9. SPECIFICATIONS	19

SYMBOLS

	Read the owner's manual.		
	Stay clear of the hot surface.		
	Exhaust gas is poisonous. Do not operate in an unventilated area.		
	Stop the engine before refueling.		
	Fire, open flame and smoking prohibited.		
	On (Run)	+	Plus ; Positive polarity
○	Off (Stop)		Battery
	Engine oil		Engine start (Electric start)
	Add oil		
	Mixing ratio of gasoline and oil for 2 cycle fuel.s.		
25~50:1			

1. SAFETY PRECAUTIONS

Please make sure to follow each precaution carefully.

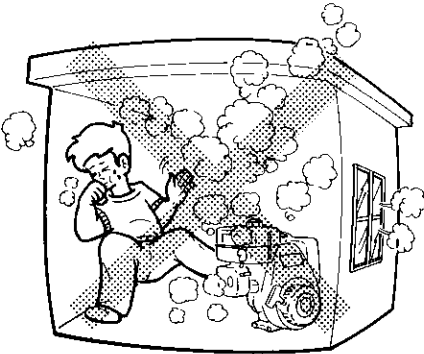

EXHAUST PRECAUTIONS

- Never inhale exhaust gasses. They contain carbon monoxide, a colorless, odorless and extremely dangerous gas which can cause unconsciousness or death.
- Never operate the engine indoors or in a poorly ventilated area, such as tunnel, cave, etc.
- Exercise extreme care when operating the engine near people or animals.
- Keep the exhaust pipe free of foreign objects.

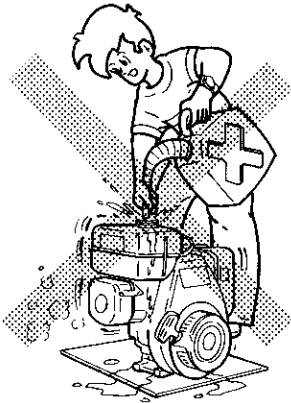

REFUELING PRECAUTIONS

- Be sure to stop the engine prior to refueling.
- Do not overfill the fuel tank.
- If fuel is spilt, wipe it away carefully and wait until the fuel has dried before starting the engine.
- After refueling, make sure that the fuel cap is secure to prevent spillage.

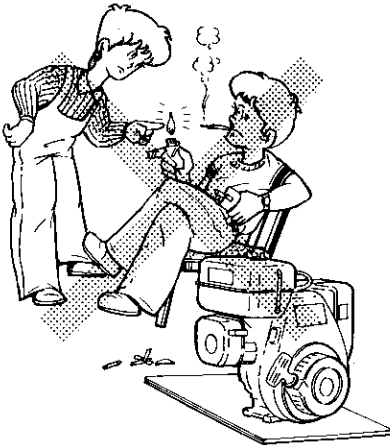

FIRE PREVENTION

- Do not operate while smoking or near an open flame.
- Do not use around dry brush, twigs, cloth rags, or other flammable materials.
- Keep the engine at least 3 feet (1 meter) away from buildings or other structures.
- Keep the engine away from flammables and other hazardous materials (trash, rags, lubricants, explosives).

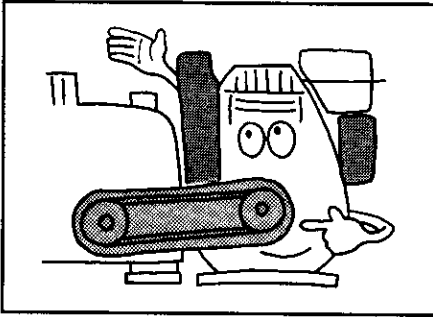

PROTECTIVE COVER

- **Place the protective covers over the rotating parts.**

If rotating parts such as the drive shaft, pulley, belt, etc. are left exposed, they are potentially hazardous. To prevent injury, equip them with protective covers or shrouds.

- **Be careful of hot parts.**

The muffler and other engine parts become very hot while the engine is running or just after it has stopped.

Operate the engine in a safe area and keep children away from the running engine.

- **Never make adjustments on the machinery while it is connected to the engine, without first removing the ignition cable from the spark plug.**

Turning over the machinery by hand during adjusting or cleaning might start the engine, and machinery with it, causing serious injury to the operator.

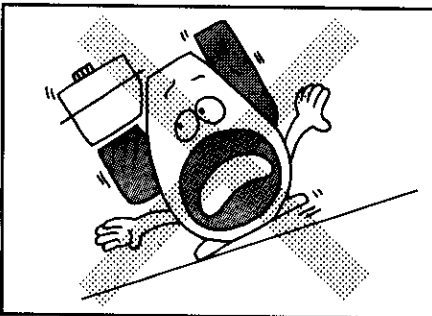

SURROUNDINGS

- **Operate the engine on a stable, level surface free of small rocks, loose gravel, etc.**

- **Operate the engine on a level surface.**

If the engine is tilted, fuel spillage may result.

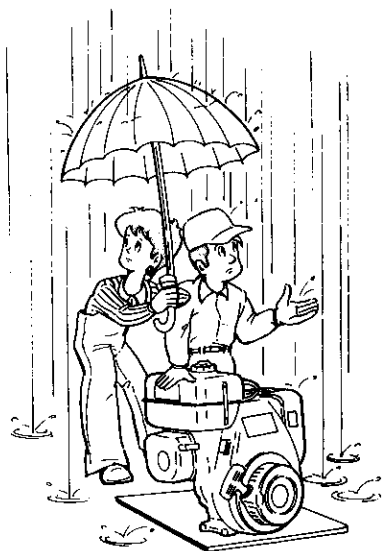

- **Be careful of fuel spillage when transporting the engine.**

Tighten the fuel tank cap securely and close the fuel strainer cock before transit.

- **Do not move the engine while in operation when it has been removed from the equipment.**

- **Keep the unit dry (do not operate it in rainy conditions).**

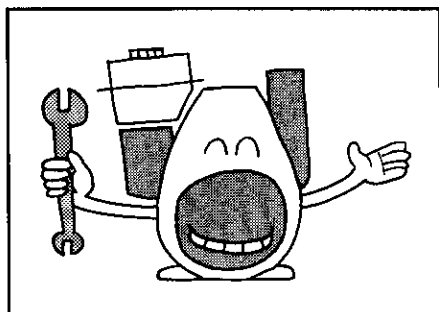

PRE-OPERATION CHECKS

- **Carefully check fuel pipes and joints for looseness and fuel leakage.**

Leaked fuel creates a potentially dangerous situation.

- **Check bolts and nuts for looseness.**

A loose bolt or nut may cause serious engine trouble.

- **Check the fuel level and refill if necessary.**

Take care not to overfill the tank.

- **Wear snug fitting working clothes when operating the engine.**

Loose aprons, towels, belt, etc., may be caught in the engine or drive train, causing a dangerous situation.

2. COMPONENTS

[FLOAT TYPE CARBURETOR]

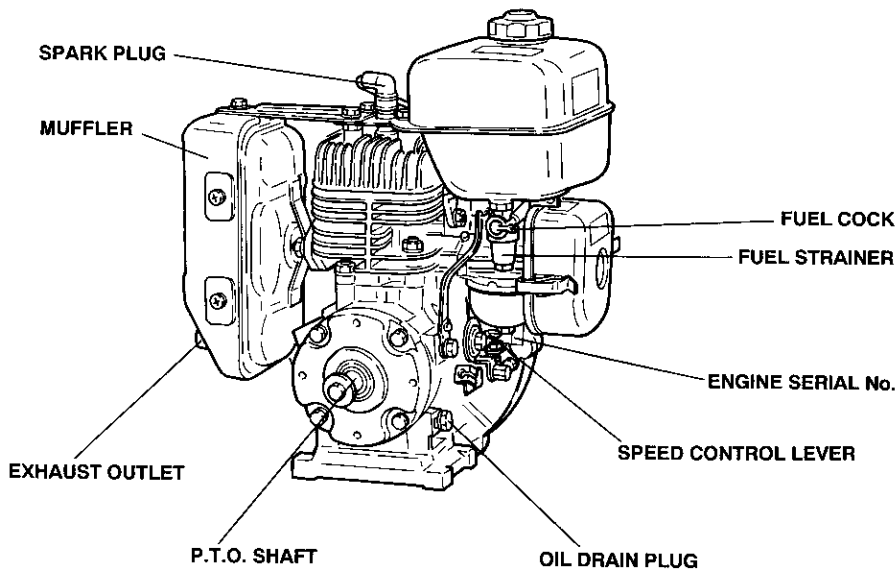
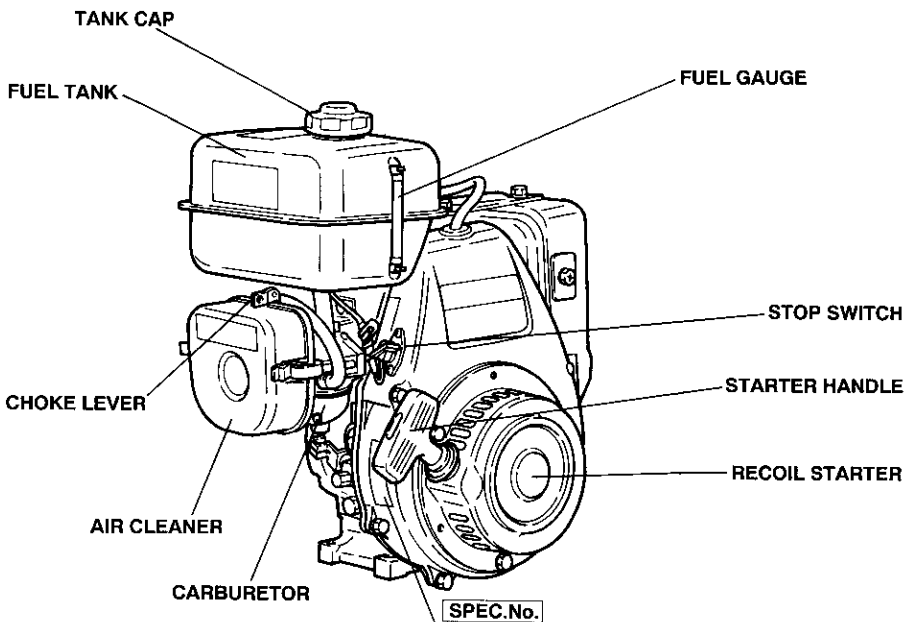

[DIAPHRAGM TYPE CARBURETOR]

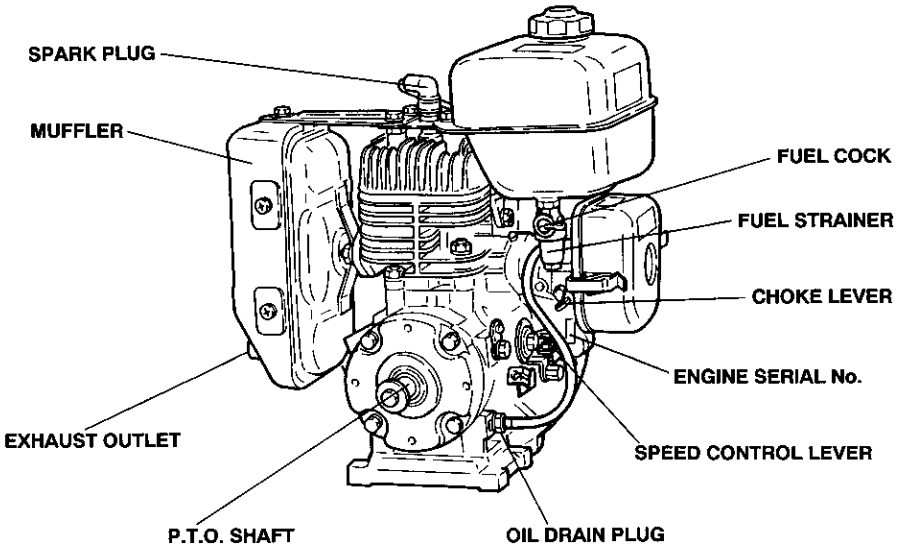
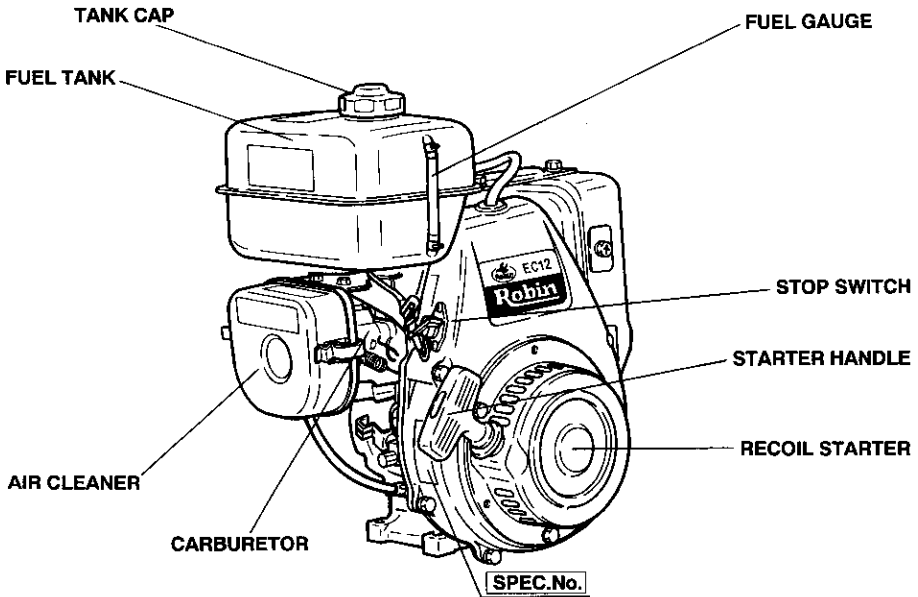

3. PRE-OPERATION CHECKS

CHECK FUEL

- The fuel tank capacity is approx. 2.5 liters.
- Use the mixture fuel prepared by mixing gasoline and exclusive 2-cycle oil at a ratio of 50:1, or the 2-cycle fuel now available on the market.
- For break-in of a new engine, use mixture fuel of gasoline 20:1 2-cycle engine oil, during first ten hours of operation.
- Close fuel cock before refilling fuel tank.
- Use fuel strainer provided at the fuel filler whenever adding fuel.
- Wipe off spilt fuel before starting engine.



WARNING

- Do not smoke while refueling.
- Be sure to stop the engine before refueling.

4. OPERATING YOUR ENGINE

[FLOAT TYPE CARBURETOR]

STARTING

STOP SWITCH

1

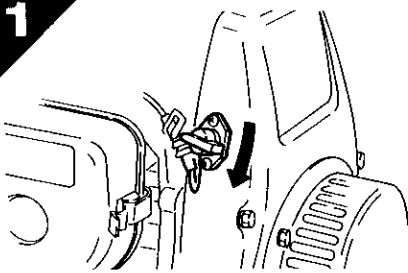

Turn the STOP SWITCH clockwise to the position "I".

SPEED CONTROL LEVER

3

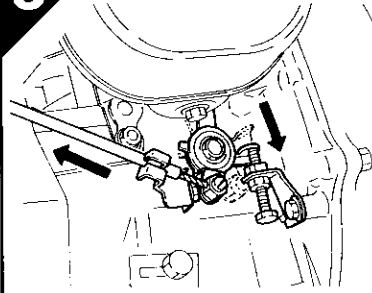

Set the speed control lever in the high speed position.

FUEL COCK

2

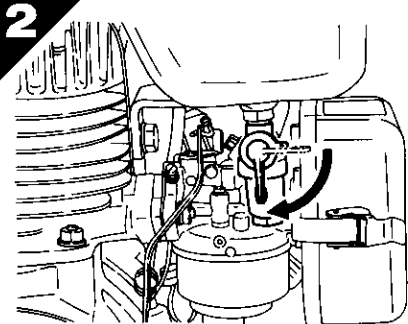

Open the fuel cock.

CHOKE LEVER

4

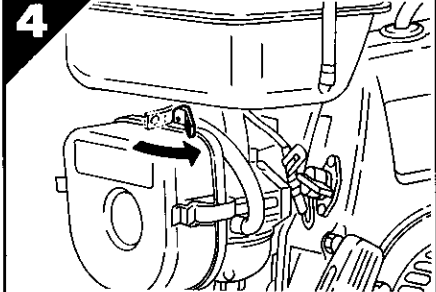

Close the choke lever.

- If the engine is warm or the ambient temperature is high, close the choke lever half-way, or keep it open fully.
- If the engine is cold or the ambient temperature is low, close the choke lever.

RUNNING

RECOIL STARTER

5

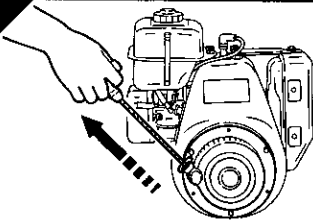

- Pull the starter handle slowly until resistance is felt. This is the "compression" point. Return the handle to its original position and pull swiftly.
- Do not pull out the rope all the way.
- After starting the engine, allow the starter handle to return to its original position while still holding the handle.

CHOKE LEVER

6

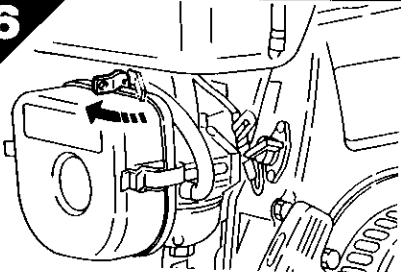

- After starting the engine, gradually open choke by turning the choke lever and finally keep it fully opened.
- Do not fully open the choke lever immediately when the engine is cold or the ambient temperature is low, because the engine may stop.

SPEED CONTROL LEVER

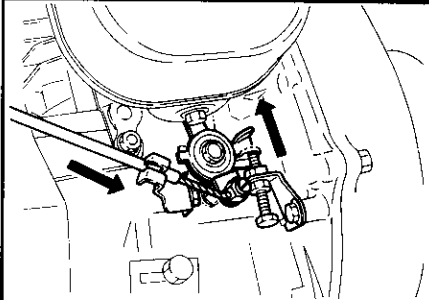

After the engine starts, set the speed control lever to the low speed position (L) and warm it up without a load for a few minutes.

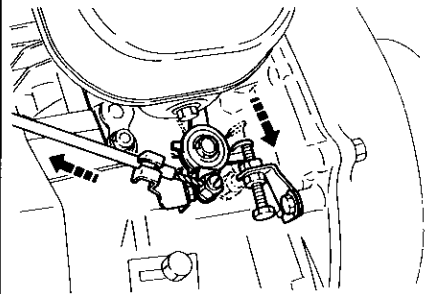

Gradually move the speed control lever toward the high speed position (H) and set it to the required engine speed.

NOTE :

Whenever high speed operation is not required, slow the engine down (idle) by moving the speed control lever to save fuel and extend engine life.

STOPPING

SPEED CONTROL LEVER

1

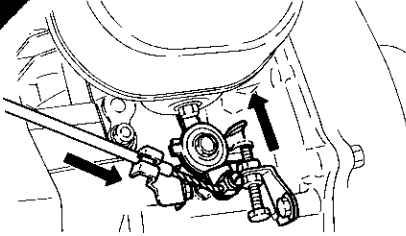

Set the speed control lever in the low speed position and allow the engine to run at low speed for 2 or 3 minutes before stopping.

STOP SWITCH

2

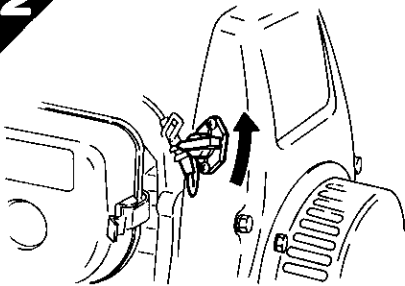

Turn the STOP SWITCH counterclockwise to the position "O".

FUEL COCK

3

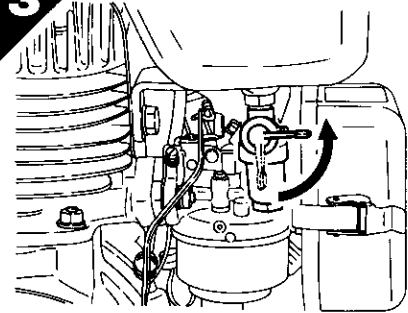

Close the fuel cock.

RECOIL STARTER

4

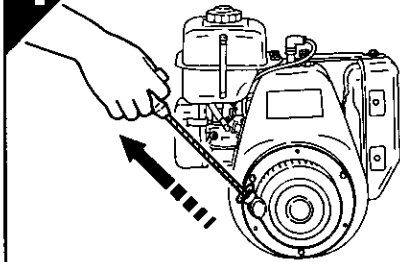

- Pull the starter handle slowly until resistance is felt then return the handle to its original position.

NOTE:

The above operation is necessary to prevent outside moist air from intruding into the combustion chamber.

[DIAPHRAGM TYPE
CARBURETOR]

STARTING

STOP SWITCH

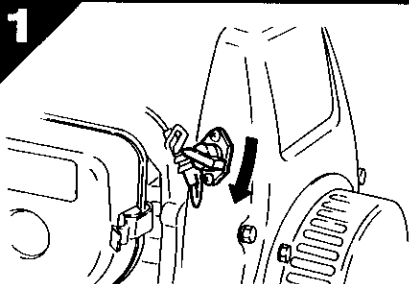
1

Turn the STOP SWITCH clock-wise to the position "I".

SPEED CONTROL LEVER

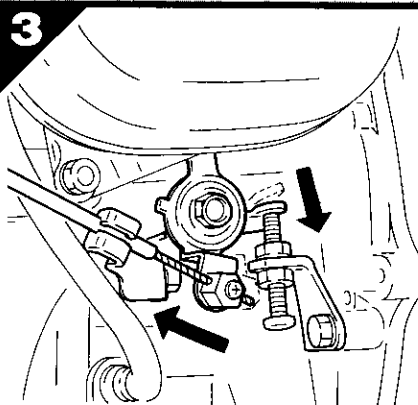
3

Set the speed control lever in the high speed position.

FUEL COCK

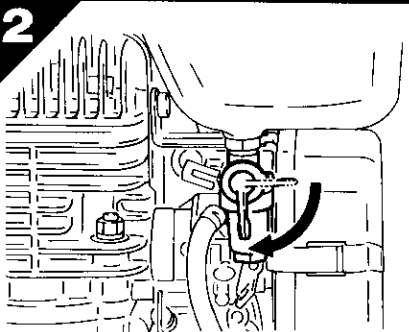
2

Open the fuel cock.

CHOKE LEVER

4

Close the choke lever.

- If the engine is warm or the ambient temperature is high, open the choke lever half-way, or keep it open fully.
- If the engine is cold or the ambient temperature is low, close the choke lever.

RUNNING

RECOIL STARTER

5

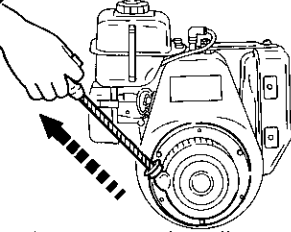

- Pull the starter handle slowly until resistance is felt. This is the "compression" point. Return the handle to its original position and pull swiftly.
- Do not pull out the rope all the way.
- After starting the engine, allow the starter handle to return to its original position while still holding the handle.

CHOKE LEVER

6

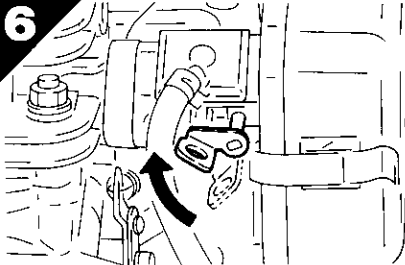

- After starting the engine, gradually open choke by turning the choke lever and finally keep it fully opened.
- Do not fully open the choke lever immediately when the engine is cold or the ambient temperature is low, because the engine may stop.

SPEED CONTROL LEVER

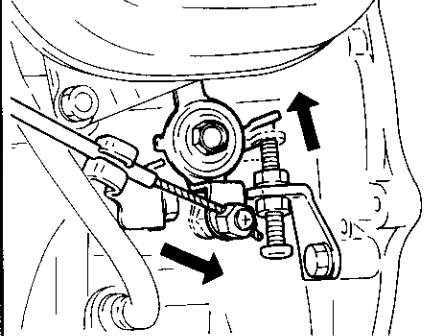

After the engine starts, set the speed control lever to the low speed position (L) and warm it up without a load for a few minutes.

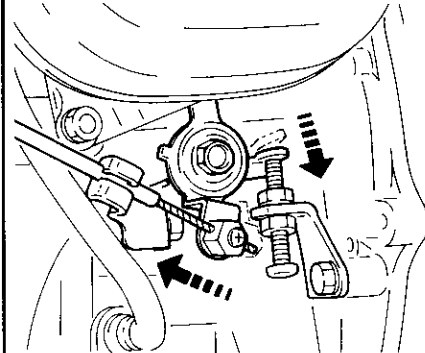

Gradually move the speed control lever toward the high speed position (H) and set it to the required engine speed.

NOTE :

Whenever high speed operation is not required, slow the engine down (idle) by moving the speed control lever to save fuel and extend engine life.

STOPPING

SPEED CONTROL LEVER

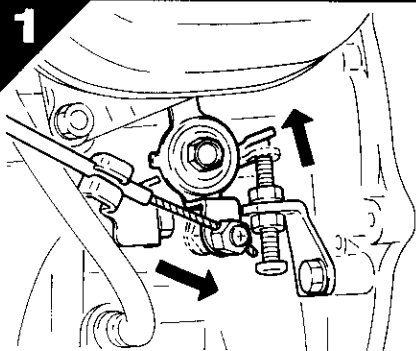
1

Set the speed control lever in the low speed position and allow the engine to run at low speed for 2 or 3 minutes before stopping.

FUEL COCK

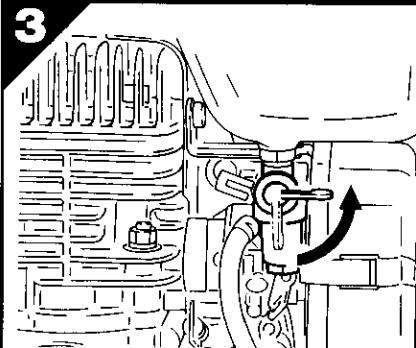
3

Close the fuel cock.

STOP SWITCH

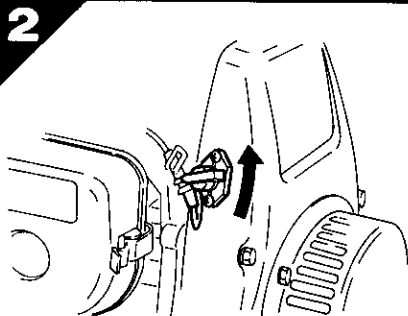
2

Turn the STOP SWITCH counterclockwise to the position "O".

RECOIL STARTER

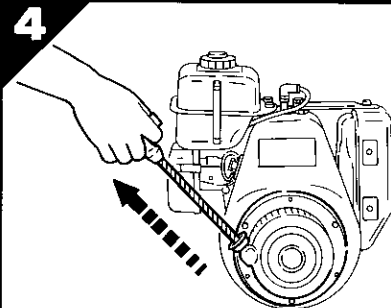
4

- Pull the starter handle slowly until resistance is felt then return the handle to its original position.

NOTE:

The above operation is necessary to prevent outside moist air from intruding into the combustion chamber.

5. EASY TROUBLESHOOTING



WHEN ENGINE DOES NOT START :

- Perform the following checks before you take the engine to your Robin dealer.
- If you still have trouble after completing the checks, take the engine to your nearest Robin dealer.

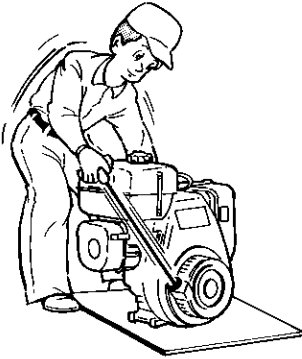

Is there enough compression ?

1. Pull the starter handle slowly and check if resistance is felt.
2. If little force is required to pull the starter handle, check if the spark plug is tightened firmly.
3. If the spark plug is loose, tighten it.

Is the spark plug wet with gasoline ?

1. Choke (close choke lever) and pull the starter handle five or six times. Remove the plug and check if its electrode is wet. If the electrode is wet, fuel is well supplied to your engine.
2. When the electrode is dry, check where the fuel stops. (Check the fuel intake of the carburetor and fuel strainer intake.)
3. In case the engine does not start with well supplied fuel, try using different fuel.

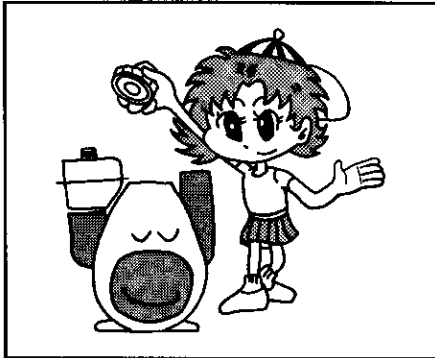

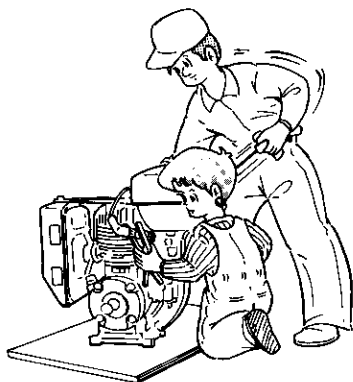

Is there a strong spark across the electrode ?

1. Remove the plug and connect it to the plug cap.
Pull the starter handle while holding the plug against the engine ground.
2. Try with a new plug if the spark is weak or there is no spark.
3. The ignition system is faulty if there is no spark with a new plug.
Take your engine to your nearest Robin dealer.



WARNING

- Before testing, carefully wipe up spilled gasoline. Hold the plug as far away from the spark plug hole as possible. Ground the side of the electrode to any engine ground.

6. MAINTENANCE SCHEDULE

DAILY INSPECTION

Before running the engine, check the following service items.

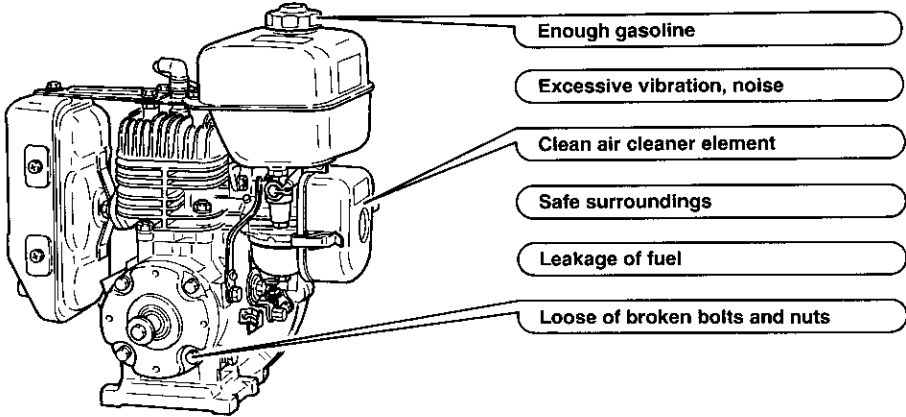

PERIODIC INSPECTION

Periodic maintenance is vital to the safe and efficient operation of your engine. Check the table below for periodic maintenance intervals.

The following chart is based on the normal engine operation schedule.

	8 hours (daily)	50 hours (weekly)	200 hours (Monthly)	500 hours
CLEAN ENGINE AND CHECK BOLTS AND NUTS	○ (daily)			
CLEAN SPARK PLUG		○		
CLEAN AIR CLEANER		○		
CLEAN FUEL STRAINER			○	
CLEAN AND ADJUST SPARK PLUG GAP			○	
CLEAN AND ADJUST CARBURETOR				○
CLEAN MUFFLER AND EXHAUST PORT				○

7. "HOW-TO" MAINTENANCE

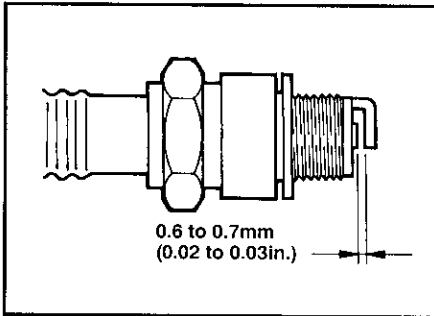

INSPECTING THE SPARK PLUG

- Clean off carbon deposits on the plug electrode using a plug cleaner or wire brush.
- Check electrode gap. Adjust it to between 0.6 mm and 0.7 mm (0.02 and 0.03 inches.)
- Recommended spark plug

NGK BM6A
CHAMPION CJ8

MAGNETO

Gap between coil core and flywheel	0.4 ~ 0.5mm
------------------------------------	-------------

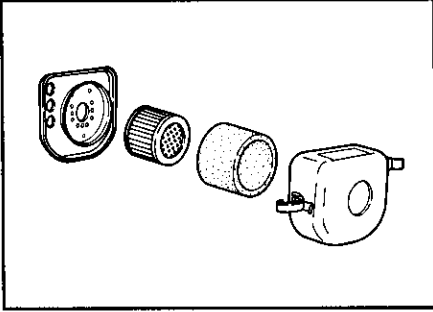

CLEANING AIR CLEANER

- If your air cleaner element is dirty, this will cause engine starting trouble, power loss, engine malfunctions, and extremely shorten engine life. Keep the air cleaner element clean.
- Remove the element and wash it in kerosene or diesel fuel. Then soak it in a mixture of 3 parts kerosene and 1 part engine oil, squeeze out the excess and install the element.

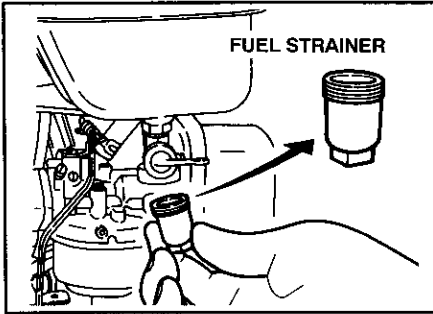

CLEANING FUEL STRAINER

- Loosen the fuel strainer from the fuel cock.
- Clean the strainer with kerosene and reassemble it.

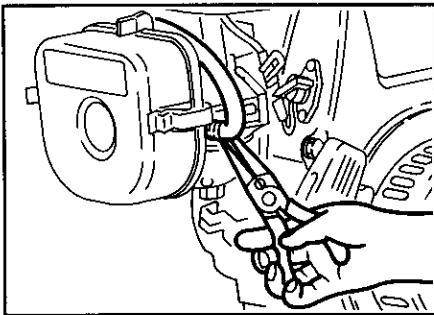

FUEL PIPE REPLACEMENT

- Replace the fuel pipe every 2 years. If the fuel leakage is found on the fuel pipe, replace it immediately.

CHECKING BOLTS, NUTS AND SCREWS

- Retighten loose bolts and nuts. Check for fuel and oil leaks. Replace damaged parts with new ones. Keep safety in your mind.

8. PREPARATIONS FOR STORAGE

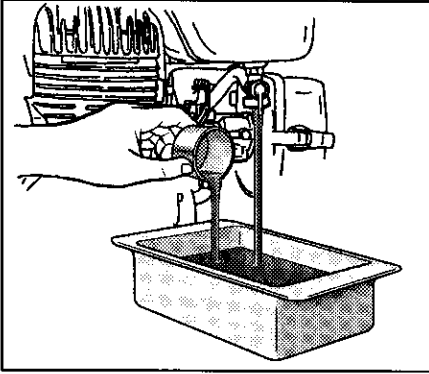

[FLOAT TYPE CARBURETOR]

DISCHARGE FUEL (NO SMOKING !)

- Remove the strainer cup. Place a pan under the strainer and discharge fuel from the fuel tank.
- Remove the carburetor float chamber bolt at the bottom and discharge fuel from the carburetor.

[DIAPHRAGM TYPE CARBURETOR]

- Close the fuel cock and run the engine until it stalls. Then, discharge fuel from the fuel tank.

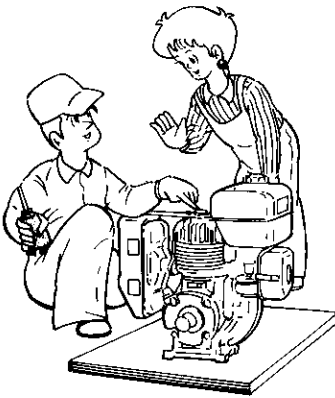

OIL

- Remove the spark plug, pour about 5 cc of engine oil into the cylinder, slowly pull the starter knob of the recoil starter 2 or 3 times, and tighten the spark plug.



CLEAN AND STORE

- Slowly pull the recoil starter handle until resistance is felt and leave it in that position.
- Clean the engine thoroughly with an oiled cloth, put the cover on, and store the engine indoors in a well-ventilated, low humidity area.

9. SPECIFICATIONS

MODEL		EC12
Type		Air-Cooled, 2-Cycle Horizontal P.T.O. Shaft.
Displacement		114 cm ³
Continuous Output		2.2KW/3600rpm (3.0HP/3600rpm)
Maximum Output		2.9KW/4000rpm (4.0HP/4000rpm)
Direction of Rotation		Counterclockwise, facing P.T.O. shaft
Fuel Tank Capacity		2.5 liters
Fuel		Mixture fuel (gasoline 50 : lubricant 1)
Spark Plug		NGK BM6A CHAMPION CJ8
Dry Weight		12 kg
Dimensions	Lenght	273mm
	Wide	327mm
	Hight	307 mm