

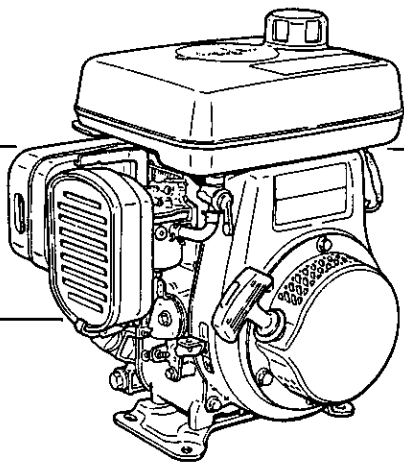

MODEL

**EY08D
EY08BN**

**INSTRUCTIONS FOR USE
MANUEL D'UTILISATION
BEDIENUNGSANLEITUNG
GEBRUIKSAANWIJZING**



CE1

ISSUE EMD-EU1383















2ZZ9990019

Robin Engines

CONTENTS

1. SAFETY PRECAUTIONS	1
2. COMPONENTS	4
3. PRE-OPERATION CHECKS	5
4. OPERATING YOUR ENGINE	6
5. EASY TROUBLESHOOTING	9
6. MAINTENANCE SCHEDULE	11
7. "HOW-TO" MAINTENANCE	12
8. PREPARATIONS FOR STORAGE	15
9. SPECIFICATIONS	16

SYMBOLS

		<p><i>Read the owner's manual.</i></p>	
		<p><i>Stay clear of the hot surface.</i></p>	
		<p><i>Exhaust gas is poisonous. Do not operate in an unventilated area.</i></p>	
		<p><i>Stop the engine before refueling.</i></p>	
		<p><i>Fire, open flame and smoking prohibited.</i></p>	
	<p><i>On (Run)</i></p>		<p><i>Plus; Positive polarity</i></p>
	<p><i>Off (Stop)</i></p>		<p><i>Battery</i></p>
	<p><i>Engine oil</i></p>		<p><i>Engine start (Electric start)</i></p>
	<p><i>Fast</i></p>		<p><i>Add oil</i></p>
	<p><i>Slow</i></p>		

1. SAFETY PRECAUTIONS

Please make sure you review each precaution carefully.

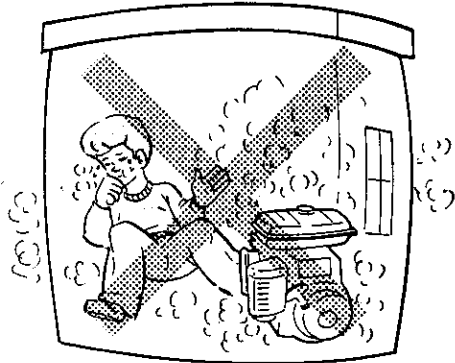

EXHAUST PRECAUTIONS

- Never inhale exhaust gasses. They contain carbon monoxide, a colorless, odorless and extremely dangerous gas which can cause unconsciousness or death.
- Never operate the engine indoors or in a poorly ventilated area, such as tunnel, cave, etc.
- Exercise extreme care when operating the engine near people or animals.
- Keep the exhaust pipe free of foreign objects.

REFUELING PRECAUTIONS

- Be sure to stop the engine prior to refueling.
- Do not overfill the fuel tank.
- If fuel is spilled, wipe it away carefully and wait until the fuel has dried before starting the engine.
- After refueling, make sure that the fuel cap is secured to prevent spillage.

FIRE PREVENTION

- Do not operate while smoking or near an open flame.
- Do not use around dry brush, twigs, cloth rags, or other flammable materials.
- Keep the engine at least 3 feet (1 meter) away from buildings or other structures.
- Keep the engine away from flammables and other hazardous materials (trash, rags, lubricants, explosives).

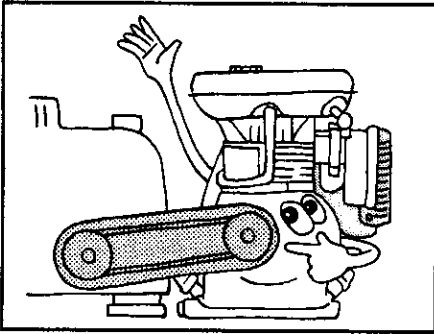

PROTECTIVE COVER

- **Place the protective covers over the rotating parts.**

If rotating parts such as the drive shaft, pulley, belt, etc. are left exposed, they are potentially hazardous. To prevent injury, equip them with protective covers or shrouds.

- **Be careful of hot parts.**

The muffler and other engine parts become very hot while the engine is running or just after it has stopped.

Operate the engine in a safe area and keep children away from the running engine.

- **Never make adjustments on the machinery while it is connected to the engine, without first removing the ignition cable from the spark plug.**

Turning over the machinery by hand during adjusting or cleaning might start the engine, and machinery with it, causing serious injury to the operator.

- **Never run the engine with governor disconnected, or operate at speeds in excess of 3600 rpm load.**

SURROUNDINGS

- **Operate the engine on a stable, level surface free of small rocks, loose gravel, etc.**

Operate the engine on a level surface.

If the engine is tilted, fuel spillage may result.

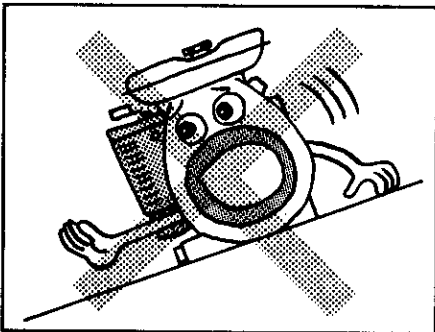

NOTE :

Operating the engine at a steep incline may cause seizure due to improper lubrication even with a maximum oil level.



- **Be careful of fuel spillage when transporting the engine.**

Tighten the fuel tank cap securely and close the fuel strainer cock before transport.

- **Do not move the engine while in operation when it has been removed from the equipment.**
- **Keep the unit dry (do not operate it in rainy conditions).**

PRE-OPERATION CHECKS

- **Carefully check fuel pipes and joints for looseness and fuel leakage.**
Leaked fuel creates a potentially dangerous situation.
- **Check bolts and nuts for looseness.**
A loose bolt or nut may cause serious engine trouble.
- **Check the engine oil and refill if necessary.**
- **Check the fuel level and refill if necessary.**
Take care not to overfill the tank.
- **Wear snug fitting working clothes when operating the engine.**
Loose aprons, towels, belt, etc., may be caught in the engine or drive train, causing a dangerous situation.

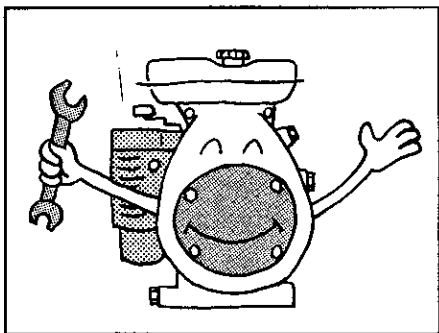

2. COMPONENTS

ENGLISH

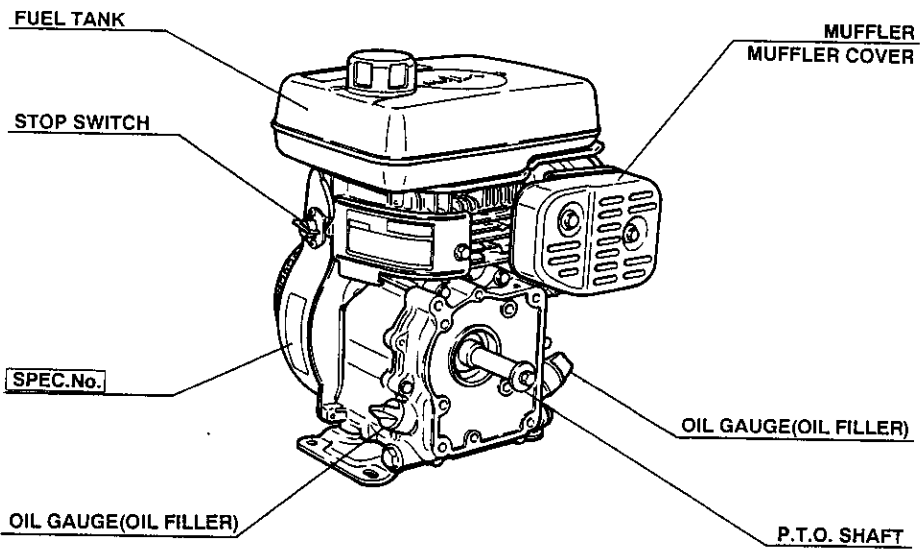
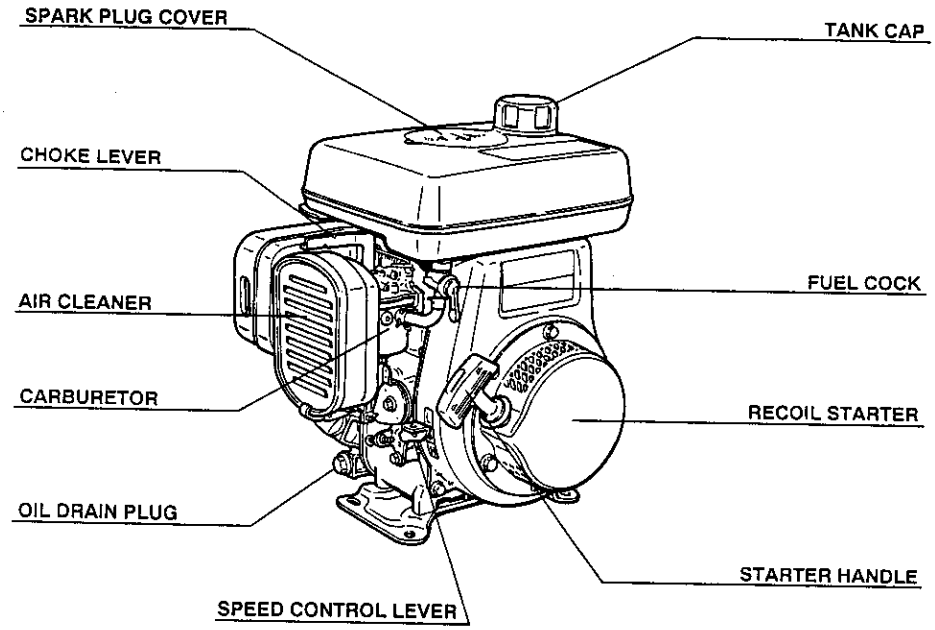

3. PRE-OPERATION CHECKS

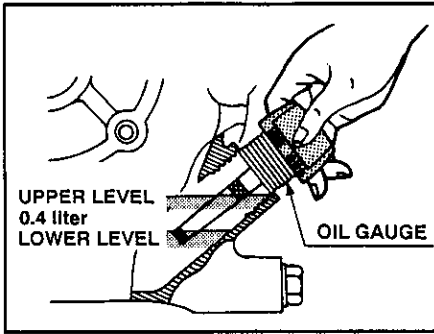

Single grade	5W							
	10W							
	20W							
	#20							
	#30							
Multi grade	10W-30							
	10W-40							
Ambient temperature	-20	-10	0	10	20	30	40°C	
	-4	14	32	50	68	86	104°F	



CHECK ENGINE OIL

Before checking or refilling engine oil, be sure the engine is located on a stable, level surface and stopped.

- Remove the oil the gauge cap.
- If the oil level is below the lower level line on the dipstick, refill with the proper oil (see table) to edge of the oil filler.
- Change oil if it is contaminated. (See page 11 Maintenance Schedule.)
- Use class SC (API classification) or higher grade oil.
- If multi-grade oil is employed, oil consumption tends to increase when the ambient temperature is high.

CHECK FUEL

CAUTION

Do not refuel while smoking, near an open flame or other potential hazards.

- Stop the engine and open the cap.
- Use unleaded gasoline only.
- Close the fuel cock before filling the fuel tank.
- When filling the fuel tank, always use the fuel filter.
- Wipe off any spilled fuel before starting the engine.

4. OPERATING YOUR ENGINE

STARTING

STOP SWITCH

1

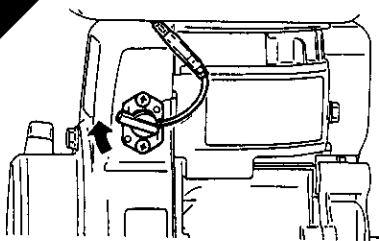

Turn the STOP SWITCH clockwise to the position "I".

FUEL COCK

2

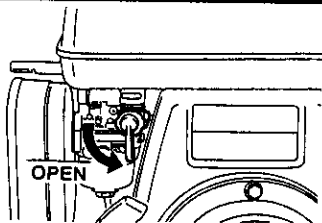

Open the fuel cock.

SPEED CONTROL LEVER

3

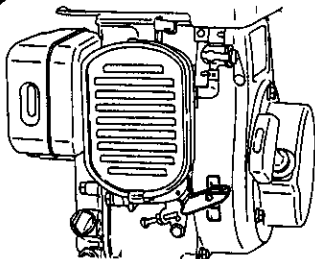

Set control lever to the "S" (starting) position.

CHOKE LEVER

4

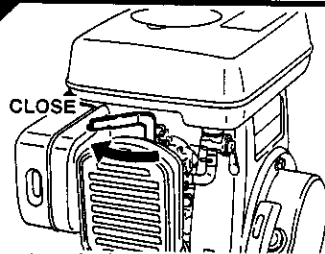

Close the choke lever.

- If the engine is warm or the ambient temperature is high, open the choke lever half-way, or keep it open fully.
- If the engine is cold, or the ambient temperature is low, close the choke lever.

RECOIL STARTER

5

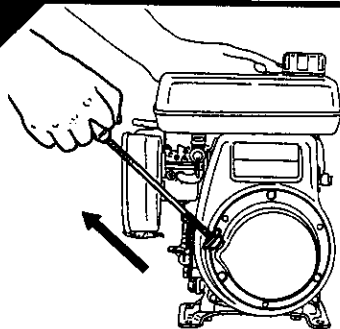

- Pull the starter handle slowly until resistance is felt. This is the "compression" point. Return the handle to its original position and pull swiftly.
- Do not pull out the rope all the way.
- After starting the engine, allow the starter handle to return to its original position while still holding the handle.

RUNNING

CHOKE LEVER

6

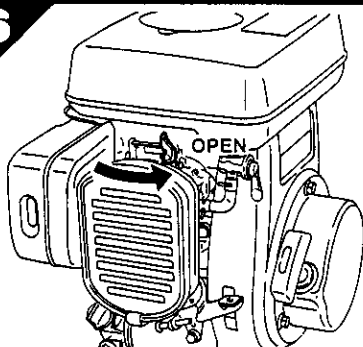

- After starting the engine, gradually open choke by turning the choke lever and finally keep it fully opened.
- Do not fully open the choke lever immediately when the engine is cold or the ambient temperature is low, because the engine may stop.

SPEED CONTROL LEVER

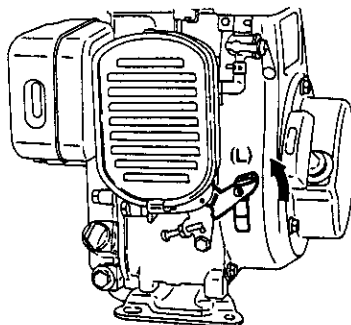

After the engine starts, set the speed control lever at the slow speed position (L) and warm it up without load for a few minutes.

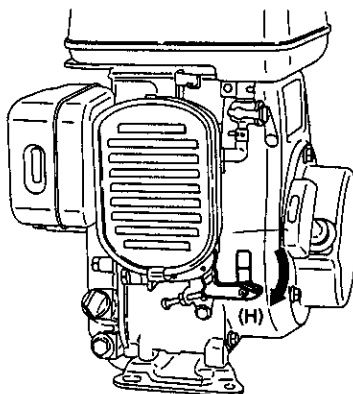

Gradually move the speed control lever toward the Fast speed position and (H) set it at the required engine speed.

NOTE :

Whenever Fast speed operation is not required, slow the engine down (idle) by moving the speed control lever to save fuel and extend engine life.

STOPPING

SPEED CONTROL LEVER

1

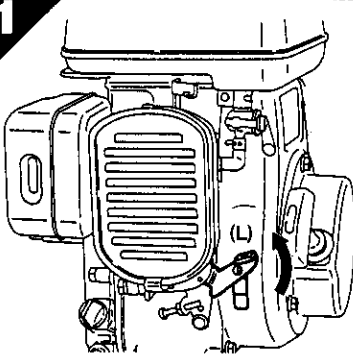

Set the speed control lever at the slow speed position and (L) allow the engine to run at low speed for 2 or 3 minutes before stopping.

STOP SWITCH

2

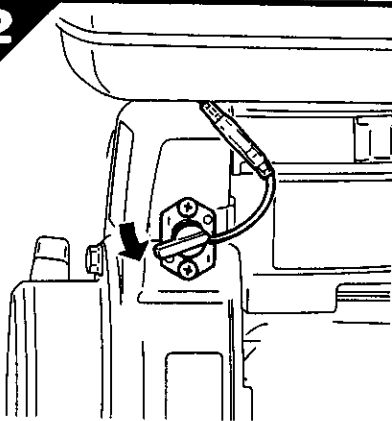

Turn the STOP SWITCH counter-clockwise to the position "O".

FUEL COCK

3

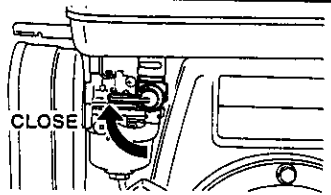

Close the fuel cock.

RECOIL STARTER

4

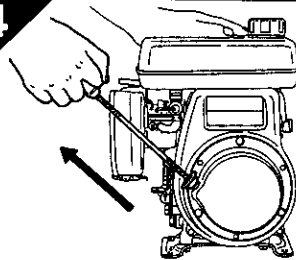

Pull the starter handle slowly and return the handle to its original position when resistance is felt.

NOTE :

The above operation is necessary to prevent outside moist air from intruding into the combustion chamber.

STOPPING ENGINE WITH THE FUEL COCK

Close the fuel cock and wait for a while until the engine stops. Avoid to let the fuel remain in the carburetor over long periods, or the passages of the carburetor may become clogged with impurities, and malfunctions may result.

5. EASY TROUBLESHOOTING

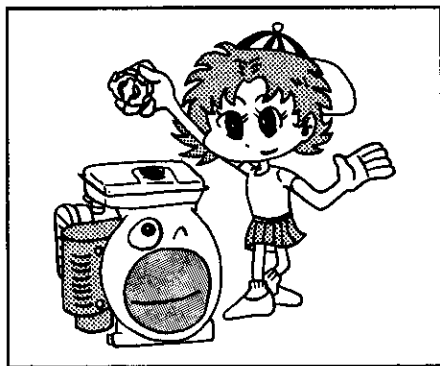

WHEN ENGINE WILL NOT START :

- Perform the following checks before you take the engine to your Robin dealer.
- If you still have trouble after completing the checks, take the engine to your nearest Robin dealer.

Is there enough compression ?

1. Pull the starter handle slowly and check if resistance is felt.
2. If little force is required to pull the starter handle, check if the spark plug is tightened firmly.
3. If the spark plug is loose, tighten it.

Is the spark plug wet with gasoline ?

1. Choke (close choke lever) and pull the starter handle five or six times. Remove the plug and check if its electrode is wet. If the electrode is wet, fuel is well supplied to your engine.
2. When the electrode is dry, check where the fuel stops. (Check the fuel intake of the carburetor and fuel strainer intake.)
3. In case the engine does not start with well supplied fuel, try using fresh fuel.



Is there a strong spark across the electrode?

1. Remove the spark plug and connect it to the plug cap.

Pull the starter handle while grounding spark plug against engine body.

2. Try with a new spark plug if the spark is weak or there is no spark.

3. The ignition system is faulty if there is no spark with a new spark plug.

Take your engine to your nearest Robin dealer.



WARNING

- Wipe out spilled fuel carefully before testing.
Place spark plug as far away from spark plug hole as possible.
- Do not hold spark plug by hand while pulling recoil starter.

6. MAINTENANCE SCHEDULE

DAILY INSPECTION

Before running the engine, check the following service items.

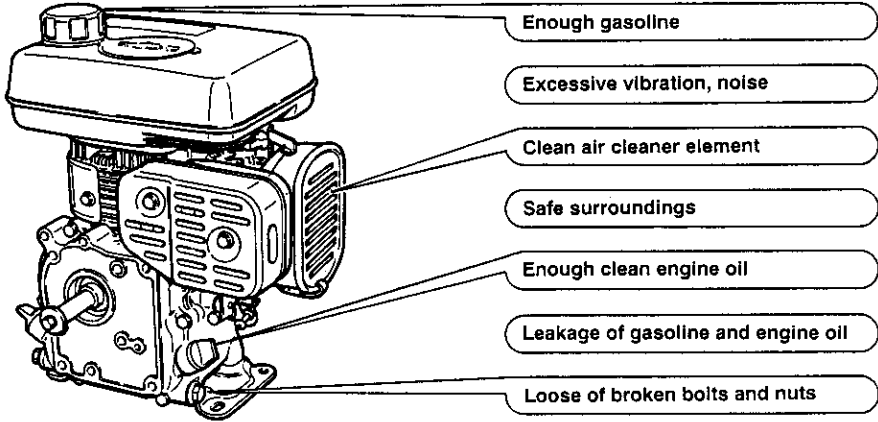

PERIODIC INSPECTION

Periodic maintenance is vital to the safe and efficient operation of your engine.

Check the table below for periodic maintenance intervals.

The following chart is based on the normal engine operation schedule.

	8 hours (daily)	50 hours (weekly)	200 hours (Monthly)	500 hours
CLEAN ENGINE AND CHECK BOLTS AND NUTS	● (Daily)			
CHECK AND REFILL ENGINE OIL	● (Refill daily up to upper limit.)			
CHANGE ENGINE OIL	● (Initial 20 hours)	●		
CLEAN SPARK PLUG		●		
CLEAN AIR CLEANER		●		
CLEAN FUEL STRAINER			●	
CLEAN AND ADJUST SPARK PLUG GAP			●	
CLEAN AND ADJUST CARBURETOR				●
CLEAN CYLINDER HEAD				●
ADJUST VALVE CLEARANCE				●
OVERHAUL ENGINE IF NECESSARY				●

7. "HOW-TO" MAINTENANCE

INSPECTING THE SPARK PLUG

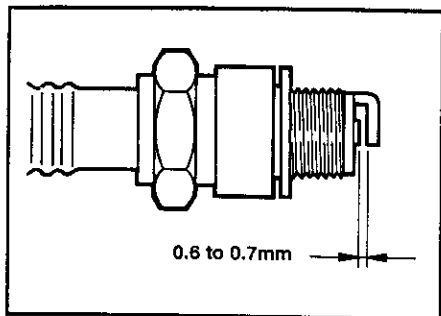

- Clean off carbon deposits on the spark plug electrode using a plug cleaner or wire brush.
- Check electrode gap.
Adjust gap 0.6 mm to 0.7 mm
- Use a proper spark plug :
BM4A (NGK)

ENGINE OIL CHANGE

WARNING

Make sure the fuel cap is tightly secured to avoid spillage.

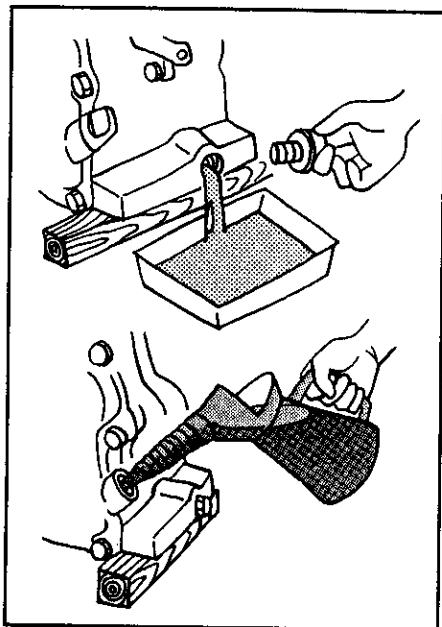

- Initial oil change
..... After 20 hours of operation
- Thereafter
..... Every 50 hours of operation

1. When changing oil, stop the engine and loosen the drain plug.
2. Re-install the drain plug before refilling oil.
3. Refer to the recommended oil table on page 5.
4. Always use the best grade and clean oil.

Contaminated oil, poor quality oil and shortage of oil cause damage to engine or shorten the engine life.

OIL CAPACITY . . . 0.4 L

CLEANING FUEL STRAINER (NO SMOKING !)

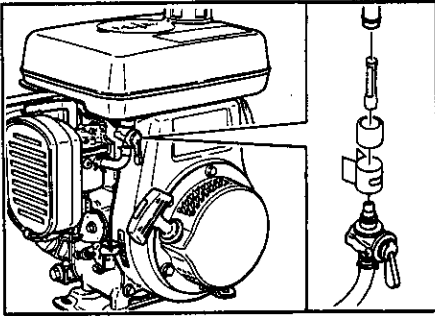

- Remove the fuel strainer from the tank.
- To remove water and dirt, close the fuel cock and remove the strainer.
- After removing dirt and water, wash the strainer with gasoline. Reinstall securely to prevent leakage.

CLEANING AIR CLEANER

Dirty air cleaner element will cause starting difficulty, power loss, engine malfunctions, and shorten engine life extremely.

Keep the air cleaner element clean.

● Urethane Foam Element

Remove the element and wash it in kerosene or diesel fuel. Then saturate it in a mixture of 3 parts kerosene and 1 part engine oil. Squeeze the element to remove the mixture and install it in the air cleaner.

● Urethane Foam Dual Structure

1. Clean the urethane foam in the same way as described above.
 2. Wash the element in kerosene or diesel fuel. With the kerosene or diesel fuel still dripping off, saturate it in a mixture of 3 parts kerosene or diesel fuel and 1 part engine oil, shake off excessive oil and reinstall.
- If an oil bath or special air cleaner with pre-cleaner is used, clean the oil pan, fill oil to the required level or clean the dust pan.

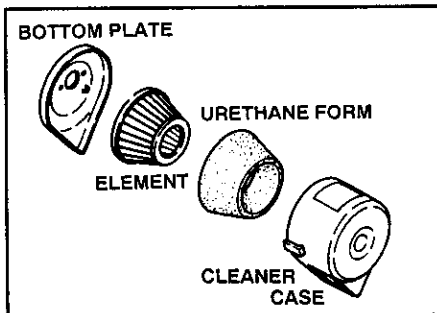
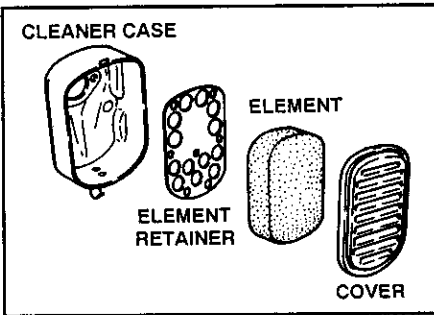

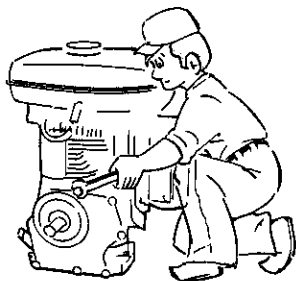

CHECKING BOLTS, NUTS AND SCREWS

Retighten loose bolts and nuts.
Check for fuel and oil leaks.
Replace damaged parts with new ones.
Keep safety in your mind.

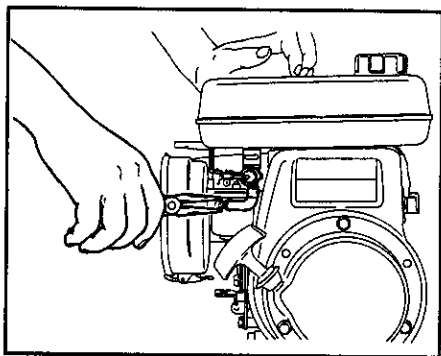

FUEL PIPE REPLACEMENT

Replace the fuel pipe every 2 years.
When fuel leak is found replace it immediately.

8. PREPARATIONS FOR STORAGE

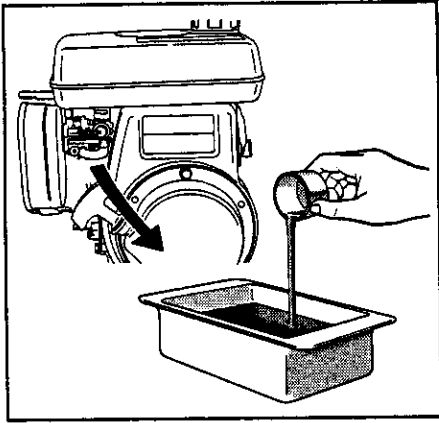

DISCHARGE FUEL (NO SMOKING !)

- Remove the fuel pipe, place the strainer over a container and open the strainer cock to discharge fuel from the fuel tank.
- Remove the carburetor float chamber bolt from the bottom and discharge fuel from the carburetor.

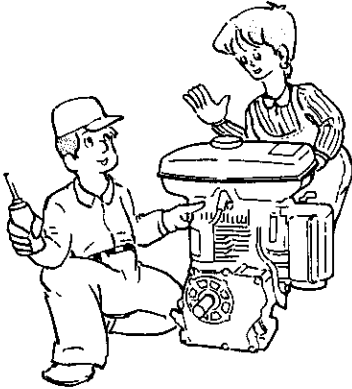

ENGINE OIL

- Change the used engine oil with fresh oil.
- Remove the spark plug, pour about 5 cc of engine oil into the cylinder, slowly pull the starter handle of the recoil starter 2 or 3 times, and re-install the spark plug.



CLEAN AND STORE

- Slowly pull the recoil starter handle until resistance is felt and leave it in that position.
- Clean the engine thoroughly with an oiled cloth, put the cover on, and store the engine indoors in a well-ventilated, low humidity area.

9. SPECIFICATIONS

MODEL		EY08D	EY08BN
Type		Air-cooled, 4-cycle, single, cylinder, p.t.o. shaft, gasoline engine	
Piston Displacement		77.6 cm ³	
Output	Maximum	1.5 KW / 4200 rpm (2.0HP/4200rpm)	1.5 KW / 2100 rpm (2.0HP/2100rpm)
	Continuous	1.0 KW / 3600 rpm (1.4HP/3600rpm)	1.0 KW / 1800 rpm (1.4HP/1800rpm)
Direction of Rotation		Counter clockwise as viewed from P.T.O. shaft side	Clockwise as viewed from P.T.O. shaft side
Lubricant		Class SC higher grade SAE #20, #30 or #40 or multi-grade engine oil	
Fuel		Automobile Gasoline	
Fuel Tank Capacity		APPROX. 1.5 L	
Spark Plug		NGK BM4A	
Starting System		Recoil Starter	
Dry Weight		8.0 kg	8.5 kg
Dimensions	Length	252 mm	
	Width	264 mm	
	Height	326 mm	

*** OPTIONAL EQUIPMENT:**

Cyclone type Air Cleaner, Throttle cable wire pulling toward P.T.O. shaft.

 **FUJI HEAVY INDUSTRIES LTD.**

INDUSTRIAL PRODUCTS COMPANY

4-410 Asahi, Kitamoto-shi,
Saitama, 364-8511, Japan

Phone +81(48) 593-7798

Fax +81(48) 593-7946

Web site <http://www.fhi.co.jp/robin/>